

## Defenda™ Child Harness

Series Number: 217/2010



### Booster Seat

For use with compatible Booster Seats for children from approximately 4 years of age up to the maximum age as stated on the Booster Seat.



### Vehicle Seat

For children approximately 7 years of age up to approximately 10 years of age when used with a lap only seat belt.

## Instructions for Installation & Use



**IMPORTANT:**  
KEEP THIS BOOKLET IN A SAFE PLACE FOR FUTURE  
REFERENCE.

Page

- 3 INTRODUCTION
- 4 INFORMATION
- 5 WARNINGS
- 6 SUITABLE FOR USE
- 7 HOW TO INSTALL & USE:  
WITH BOOSTER SEAT
- 17 HOW TO INSTALL & USE:  
WITH CAR'S SEAT
- 23 CORRECT FITMENT
- 24 NEXT TYPE OF RESTRAINT

---

- 25 PRE-INSTALLATION
- 26 PRE-INSTALLATION ANCHOR FITTING
- 29 IN CASE OF ACCIDENT
- 30 CONTACT DETAILS

The Defenda™ Harness is suitable for child use on a vehicle seat or in conjunction with any booster seat or booster cushion. It has also been specifically designed for use with the Safe-n-Sound Defenda™ Harness compliant Booster Seats to provide a safe and secure fit for the child.

Child Harnesses should be used in conjunction with a compatible booster seat by children aged at least 4 years of age whose shoulders are above the lower shoulder height marker, to at least 7 years of age and as either a stand-alone restraint or with a compatible booster by children at least 7 years of age to approximately 10 years. Children should continue to use a booster until their shoulders reach the upper shoulder height marker.

Do not use this restraint until child's shoulders are above the lower shoulder height marker on the booster seat. Children are safest in a booster.

Correct use of this product can significantly reduce a child's risk of injury.

This restraint must be used with a lap or lap-sash seatbelt in accordance with these instructions.

Protect all webbing from abrasion and cutting by sharp corners and edges.

DO NOT USE IF THE CHILD WEIGHS OVER 36kg.

THIS RESTRAINT MUST BE ATTACHED TO A CHILD RESTRAINT ANCHORAGE POINT IN THE CAR. REFER TO CAR OWNERS HANDBOOK FOR LOCATION OF ANCHORAGE POINTS. REFER TO A CHILD RESTRAINT FITTING STATION IF NO ANCHORAGE POINTS ARE IN THE MOTOR CAR.

WHEN USED WITH JUST A SEATBELT, THIS CHILD HARNESS IS TO BE USED WITH A LAP ONLY SEAT BELT IN THE BACK OF MOST CARS WITH FORWARD FACING SEATS.

IF USED WITH A BOOSTER SEAT OR BOOSTER CUSHION SEAT THEN EITHER A LAP OR A LAP-SASH SEATBELT MAY BE USED WITH THE CHILD HARNESS.

This Child Harness is not suitable where the harness needs to feed through slots in the seat back or for attachment to a **VERSATETHER™** connection.

These instructions show the installation of the Child Harness for use with a:

- Booster Seat or Booster Cushion and a Lap or lap-sash seatbelt (page 7).
- Car's seat and a lap only seat belt (page 17).

This Child Harness is not suitable for use with Booster Seats that have Upper Anchorage Straps (Tether Straps).

Safe-n-Sound recommends the Defenda™ Harness is used with the SLIDEGUARD™ clip to ensure the Child Harness fits correctly and the child does not slump under the car's lap seat belt. Lap seat belt on the child's abdomen is dangerous.

# INFORMATION

CAREFULLY READ AND FOLLOW ALL OF THE INSTRUCTIONS FOR INSTALLATION. INSTALL IN STRICT ACCORDANCE WITH THESE INSTRUCTIONS FOR MAXIMUM SAFETY. IF IN DOUBT ABOUT THE CORRECT METHOD OF INSTALLATION PLEASE CONTACT BRITAX CHILDCARE, OR AGENT OR A CHILD RESTRAINT FITTING STATION AUTHORIZED BY THE STATE GOVERNMENT BODY. IN NEW ZEALAND, CONTACT THE AGENT FOR THE VEHICLE.

No child restraint can guarantee absolute protection from injury in every crash. However, to ensure that your child gets all the protection designed into the Defenda™ Harness please READ AND FOLLOW THESE INSTRUCTIONS EXACTLY and use only Safe-n-Sound recommended parts and accessories.

This Child Harness may be used in conjunction with Booster Seats that recommend this Child Harness. Read the Booster Seat instruction book or packaging to confirm which harness you need.

## UPPER ANCHORAGE

This Child Harness requires the upper anchorage strap to be connected to a child restraint anchor fitting in the car. Recent cars include an anchor fitting where as older cars will require the fitting to be installed. Check your car owners handbook for the location of the car's child restraint anchor fitting or anchorage point. If there is no fitting then read pages 25-28. An anchor fitting is provided with this product which can be used if there is no anchor fitting in the car.



## CHOOSING METHOD OF INSTALLATION

The harness may be used with compatible Booster Seats or Convertible Booster Seats, using either the car's lap only seat belt or the lap sash seat belt until the child is too large for the booster seat, that is the child's shoulders reach the Upper Shoulder Height Marker (see pages 7 to 16).

The harness can be used with a lap only seat belt in a car for children 7 years of age and over (See pages 17 to 22).

## ⚠ WARNINGS

**DO NOT USE IF THE CHILD WEIGHS OVER 36kg.**

**Use the restraint exactly as shown in the instructions.**

**Supervision of children is needed because they may be able to undo buckles.**

**Do not alter or modify this restraint.**

**Repairs must only be done by the manufacturer or agent.**

**Do not allow the restraint to come into contact with polishes, oils, bleach & other chemicals.**

**Destroy the restraint if it has been in a severe crash, even if no damage is visible.**

**The lap portion of the belt must be adjusted firmly first, and then the harness, so that the belt is not lifted off the child's lap when the harness is adjusted.**

**DO NOT USE THIS HARNESS IF THE CHILD'S SHOULDERS ARE ABOVE THE TOP OF THE CAR SEAT BACK OR HEADREST (Unless child is seated on a booster seat with head support above the car seat back).**

**Straps may be damaged by unsecured cargo in a collision. Secure or remove hazardous cargo before using this strap.**

**Hatch-back or wagon: Do not use the child restraint where this strap may fall into a split in the seat back.**

**A seat belt extender should not be used if the seat belt is not long enough to secure the child. If a seat belt extender is used then the buckle must not be in contact with the child.**

## ⚠ WARNING:

**DO NOT LEAVE CHILDREN UNATTENDED IN THE CAR.**

## INSTALLATION AND USE

THIS RESTRAINT MUST BE ATTACHED TO A CHILD RESTRAINT ANCHORAGE POINT IN THE CAR. REFER TO CAR OWNERS HANDBOOK FOR LOCATION OF ANCHORAGE POINTS. REFER TO A CHILD RESTRAINT FITTING STATION IF NO ANCHORAGE POINTS ARE IN THE MOTOR CAR.

TO BE USED WITH A LAP ONLY SEAT BELT IN THE BACK OF MOST CARS WITH FORWARD FACING SEATS.

TO BE USED WITH A LAP ONLY SEAT BELT IN THE BACK OF MOST CARS WITH FORWARD FACING SEATS. IF USED WITH A BOOSTER SEAT THEN EITHER A LAP OR LAP-SASH SEATBELT MAY BE USED WITH THE CHILD HARNESS.

# SUITABLE FOR USE

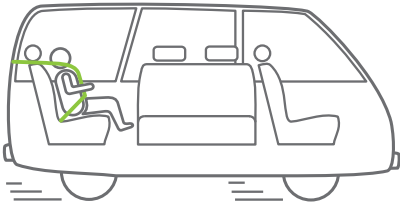

TO BE USED WITH A LAP OR LAP-SASH SEAT BELT IN THE BACK OF MOST CARS WITH FORWARD-FACING SEATS.

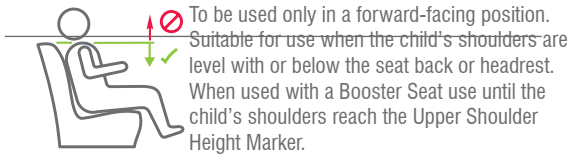
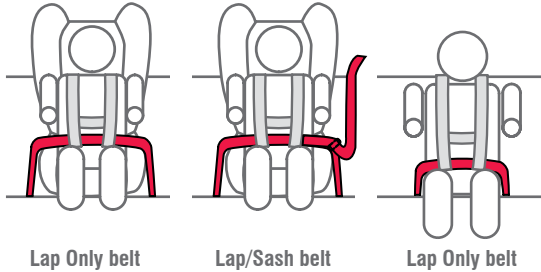

## NOT SUITABLE FOR USE

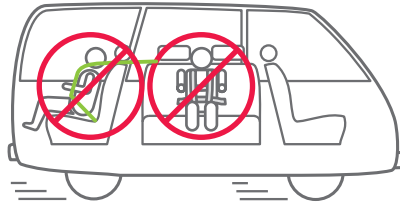

Do not use on any vehicle seat which faces sideways or rearwards.

## PARTS SUPPLIED IN THE PACKAGE:

- Defenda™ Harness
- Anchor fitting, bolt and spacers.
- Gated 3 bar slide
- Instruction Booklet

# HOW TO INSTALL & USE

WITH BOOSTER SEAT

## USING WITH A BOOSTER SEAT OR BOOSTER CUSHION

The Defenda™ Harness is suitable for Booster Seats or Booster Cushions for seating positions where a child restraint anchorage fitting is provided. Refer to the car's owners manual for positions. If an anchor fitting is required refer to pages 25-28 as you will need to install a Child Restraint anchor fitting.

The following instructions provide details for installing the Child Harness with a typical Booster seat for either a lap only seat belt or a lap-sash seat belt.

**CAUTION:** ALWAYS FOLLOW THE BOOSTER SEAT OR BOOSTER CUSHION INSTRUCTIONS AND LABELLING.

## INSTALLING INTO VEHICLE

Hook the Child Harness attachment clip (1) onto anchor fitting in the car. Ensure that none of the straps are twisted and not passing over any sharp edges.

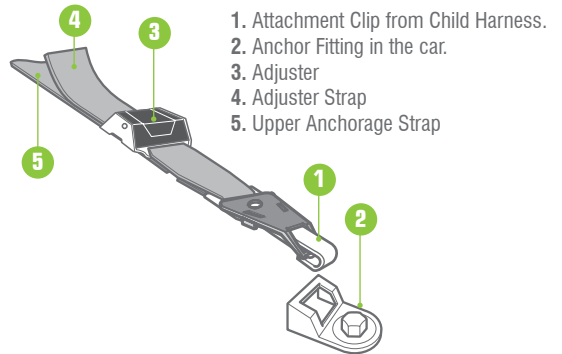

The Child Harness can be adjusted by pulling on the Adjuster Strap (4) but only do this after the seat belt has been adjusted. To slacken the Child Harness, rotate the adjuster upwards and pull the Upper Anchorage Strap (5)

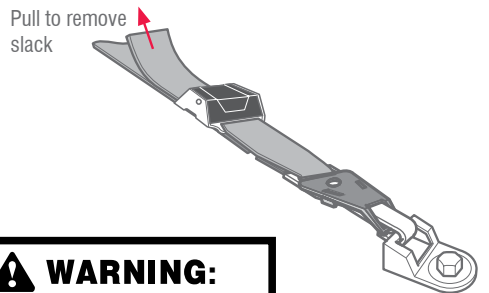

**WARNING:**

Always attach the hook and remove the slack.

# HOW TO INSTALL & USE

## FOR USE WITH A LAP-SASH SEAT BELT AND BOOSTER SEAT

There may be one of two types of Gated Slides available as shown below provided with this harness. Only use Gated Slides recommended for this Harness.

If curved Gated Slide, then the belt route through this can only go one way as shown.

Before using the Defenda™ Harness with a Lap-Sash Seat Belt, you need to convert the seat belt to a Lap Seat Belt by using the Gated Slide provided.

**IMPORTANT:** Face the hollow side of the Gated Slide towards the child. Do not use Gated Slide for any other purpose.

Curved

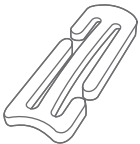

Flat

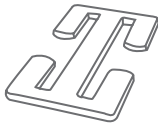

**Always ensure the Hollow side is towards child**

**A.** Hold the lap and sash straps together and fold as shown below. Slide the inner strap into the Gated Slide followed by the outer strap.

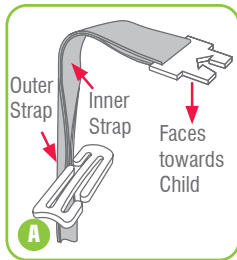

**B.** The two straps should slide freely in the Gated Slide slot.

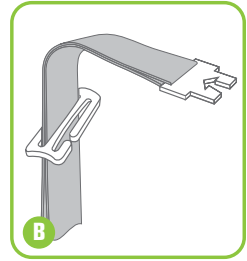

**C.** Repeat previous step A for the other slot in the Gated Slide.

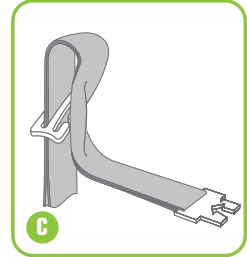

**D.** Feed the straps through the Gated Slide to remove any slack. This has now converted the lap-sash seat belt so it will act like a lap only seat belt.

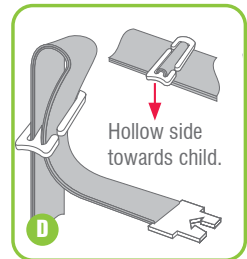
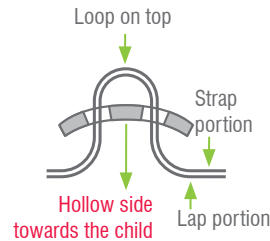

**TO ENSURE CORRECT CONVERSION OF LAP-SASH SEAT BELT TO LAP SEAT BELT FOLLOW THESE STEPS.**

### **! IMPORTANT:**

The Gated Slide must be removed from the seat belt if the booster seat and child harness are no longer used in the car so that other users can use the seat belt as a lap sash seat belt.

A seat belt extender should not be used if the seat belt is not long enough to secure the child. If a seat belt extender is used then the buckle must not be in contact with the child.

# HOW TO INSTALL & USE

## CHOOSING THE UPPER OR LOWER LOOPS OF THE CHILD SAFETY HARNESS

The harness features two sets of loops to take the car's seat belt.

### Smaller children on booster seats.

**The upper loops must be used**, if the cross strap is positioned too close to the child's throat, these loops may also be used if the vehicle anchorage point is located too close to the vehicle seat back, provided the back of child's neck is not contacting the webbing.

### Larger children

**The lower loops must be used**, when the back of child's neck is contacting the webbing of the child harness when using the upper loops.

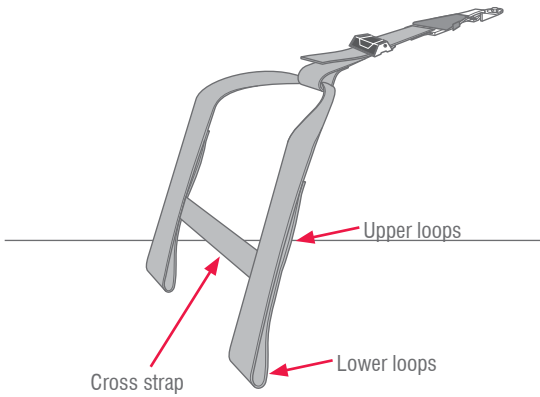

# HOW TO INSTALL & USE

## HARNESSING THE CHILD INTO THE BOOSTER SEAT

These instructions apply to fitting with a lap only seatbelt or a converted lap-sash seatbelt.

- A. Create some slack in the Upper Anchorage Strap.
- B. Hook the Attachment Clip to the car's Anchor Fitting.

Refer to the car's owner manual for location of the anchor fitting. If there is no anchor fitting, refer to pages 25-28.

- C. With the child seated, place each of the harness straps over each shoulder.
- D. Feed the adult belt (lap belt or converted lap/sash) through either the Upper Harness Strap Loops for smaller children or the Lower Harness Strap Loops for larger children. The top of the harness must not be a tight fit on the child's neck, if so, use the Lower Harness Strap Loops. Ensure there are no twists in the harness or seat belt.

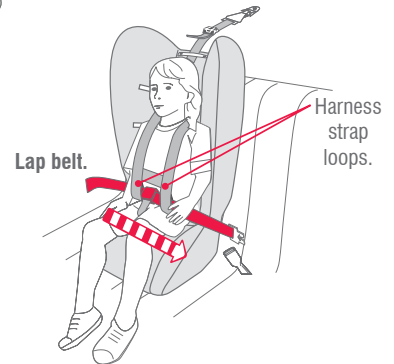
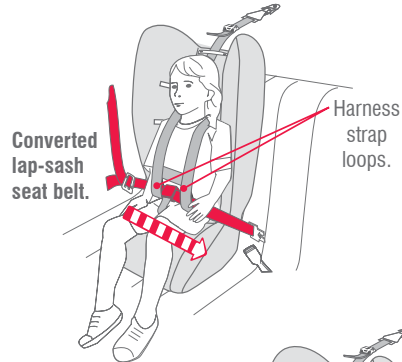

WITH BOOSTER SEAT

WITH BOOSTER SEAT

# HOW TO INSTALL & USE

E. Engage the car's seat belt tongue to the buckle and adjust the seat belt to sit firmly around the child's hips and thighs. The seat belt buckle should be located as low as possible below the child's hip. If using a lap-sash seatbelt and Gated Slide you will need to adjust it so that the seatbelt is firm on the child's thighs and the Gated Slide is close to the Child but not touching the child.

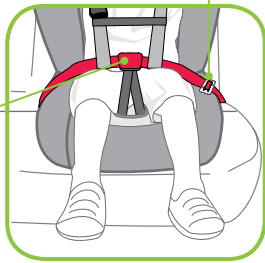
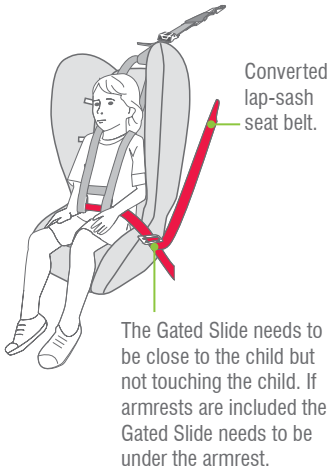

F. Fit the SLIDEGUARD™ clip if provided on the Booster Seat or any Lap Belt Positioning Device to the lap seat belt.

G. Then adjust the Defenda™ Harness to remove slack in the shoulder straps. Do not over tighten so as to cause the seatbelt to lift off the child's thighs. As the child grows this front adjuster will need to be adjusted.

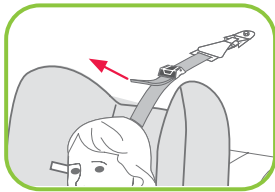

## **⚠ WARNING:**

The lap portion of the belt must be adjusted firmly first, and then the harness, so that the belt is not lifted off the child's lap when the harness is adjusted. The shoulder straps do not need to be tight.

# HOW TO INSTALL & USE

## Defenda™ HARNESS WITH BASIC BOOSTER AND BOOSTER CUSHION

### USING LAP SASH SEATBELT

Thread the converted lap-sash seat belt through the harness strap loops as shown.

#### Smaller Child - Upper Loops

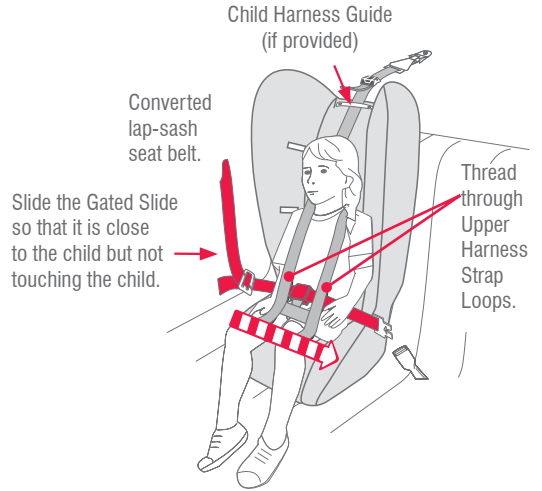

#### Larger Child - Lower Loops

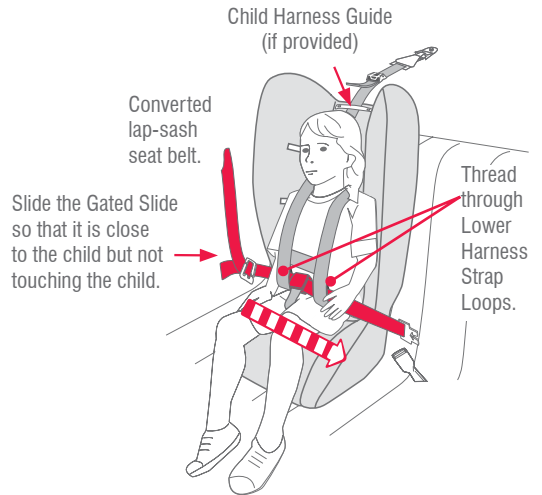

WITH BOOSTER SEAT

# HOW TO INSTALL & USE

## USING LAP ONLY SEATBELT

Thread the lap seat belt through either the Upper Harness Strap Loops or Lower Harness Strap Loops.

### Smaller Child - Upper Loops

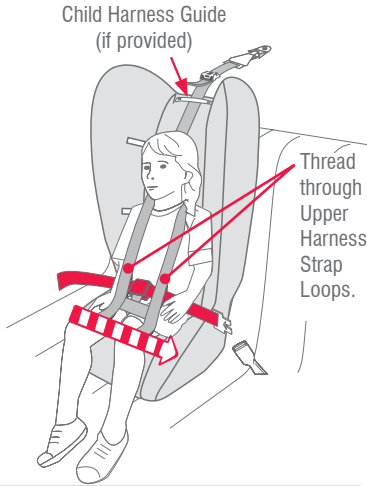

### Larger Child - Lower Loops

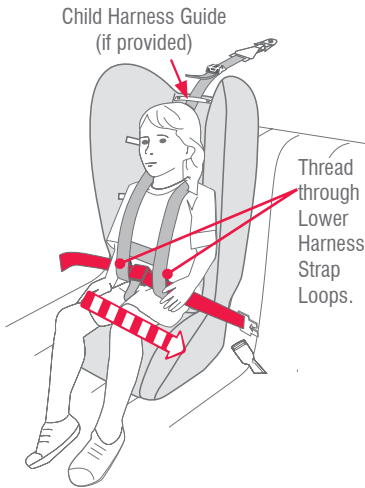

**WARNING:**

**DO NOT LEAVE CHILDREN UNATTENDED IN THE CAR.**

# HOW TO INSTALL & USE

Engage the seat belt and always ensure the lap belt is firm on the hips and thighs. Adjust the harness to just remove slack and not tight such that lap belt is lifted off the thighs.

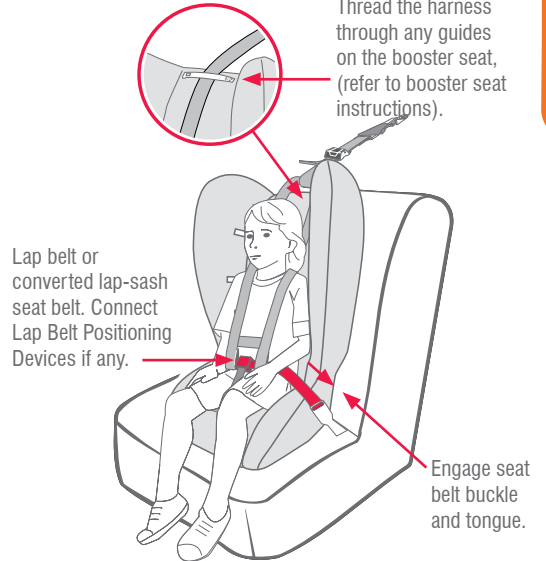

## USE WITH A BOOSTER CUSHION

Follow the previous instructions for Booster Seats.

**IMPORTANT:**

The child's shoulders must be below the top of the car's seat back or the car's headrest.

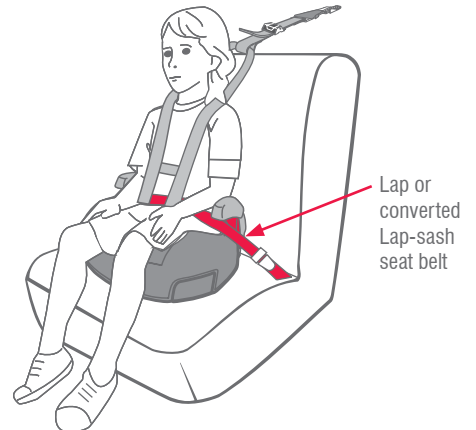

Shoulders must not be above the top of the car's seat back.

**Note:** refer to page 7 for the adjustment of the child harness

WITH BOOSTER SEAT



# HOW TO INSTALL & USE

# HOW TO INSTALL & USE

## TO REMOVE CHILD FROM HARNESS AND SEAT

Disengage seat belt tongue and buckle, remove the lap portion of seat belt from the Lap Belt Positioning Device (where provided) and remove Child Harness and seatbelt from child.



Lift child harness strap over child's head.

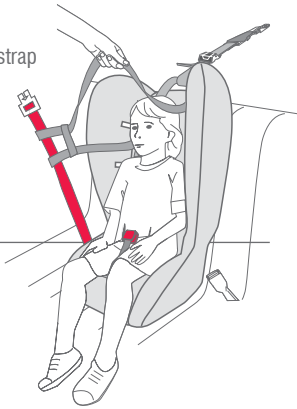

## TO LARGE FOR A BOOSTER SEAT

Once the child is too large for the booster seat, the child's shoulder's reach the Upper Shoulder Height Marker, the Child Harness can then be used with a lap only seat belt on the car's seat. A Child Harness is a significant safety device for children in a lap only seat belt. Refer to the following pages.

Upper Shoulder Height Marker

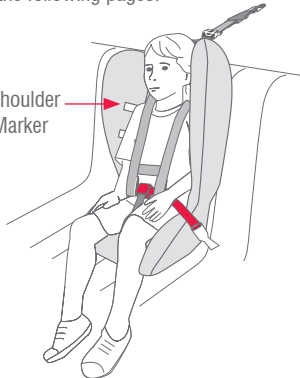

## USING THE HARNESS WITH THE CAR'S SEAT AND SEATBELT

This mode is used after the child has finished using a Booster Seat or Convertible Booster Seat because their shoulders were in line with the Upper Shoulder Height Marker. If you have not already done so, check your car owner handbook for the location of the car's child restraint anchor fitting. If there is no anchor fitting then read pages 25-28.

When installing the Defenda™ Harness into the vehicle connect the upper anchorage strap to the anchor fitting on the parcel shelf or behind the seat.

Use the Extension Strap (an accessory) for all other instances requiring a longer strap to attach the harness to anchor points in the vehicle floor or roof (See page 25).

WITH CAR'S SEAT

# HOW TO INSTALL & USE

## INSTALLING INTO VEHICLE

Hook attachment clip onto anchor fitting. Ensure that the straps are not twisted or catching on sharp edges.

1. Attachment Clip from Child Harness.
2. Anchor Fitting in the car.
3. Adjuster
4. Adjuster Strap
5. Upper Anchorage Strap

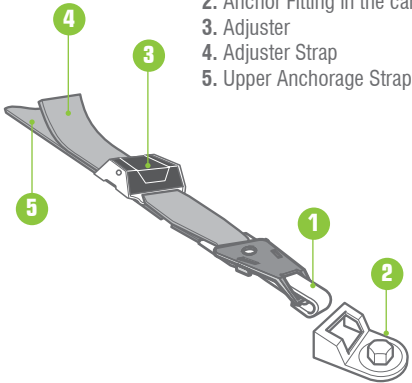

The Child Harness can be adjusted by pulling on the Adjuster Strap (4) but only do this after the seat belt has been adjusted. To slacken the Child Harness, rotate the adjuster upwards and pull the Upper Anchorage Strap (5)

Pull to remove slack

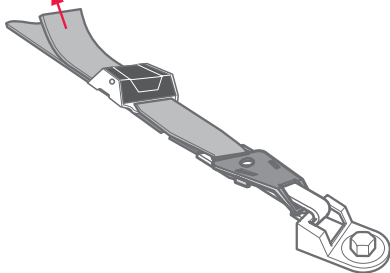

### **WARNING:**

**Always attach the hook and remove the slack.**

# HOW TO INSTALL & USE

## **IMPORTANT:**

**If you have used the Harness with a Lap-sash Seat belt, then the Gated Slide must be removed from the seat belt if the booster seat and harness are no longer used in the car so that other users can use the seat belt as a lap sash seat belt.**

**A seat belt extender should not be used if the seat belt is not long enough to secure the child. If a seat belt extender is used then the buckle must not be in contact with the child.**

- A. Create some slack in the Upper Anchorage Strap.
- B. Connect the Defenda™ Harness Attachment Clip to the Child Anchorage fitting in the car as described on the previous pages.
- C. With the child now seated in the car, place the shoulder straps on each side of the child's neck.



WITH CAR'S SEAT

# HOW TO INSTALL & USE

- D Thread the lap seat belt through the Lower Harness Strap Loops harness strap loops as shown. If you are using a Lap-sash seat belt, refer to page 13 for converting the seat belt.

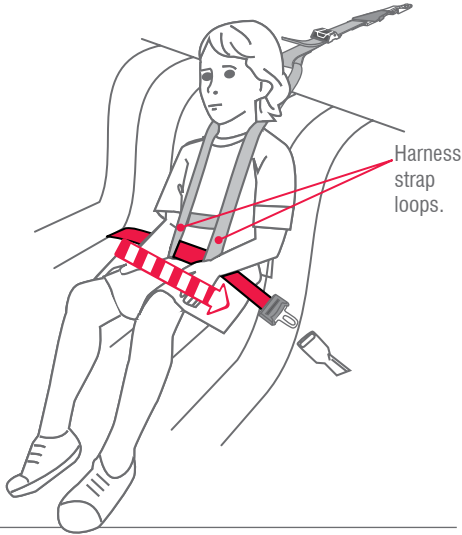

- E. Engage car's Seat belt buckle and Tongue. Tighten the lap seat belt so that it fits firmly on the child's thighs. **The child must not slump or slouch such that the seat belt rides up on the abdomen or tummy of the child.**
- F. Remove the slack in the Child Harness by pulling the Adjuster Strap. Do not tighten as this may lift the seat belt from the child's thighs. Some slight slack in the shoulder straps is preferable.

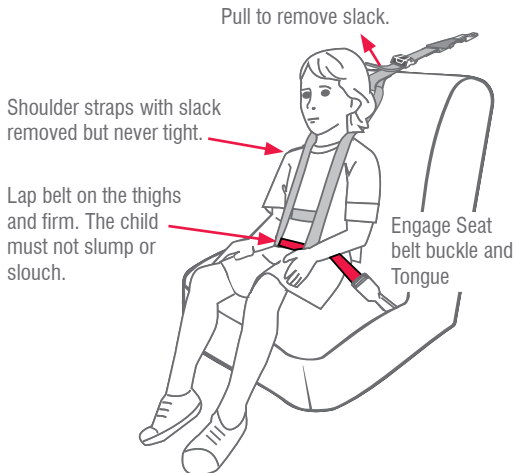

# HOW TO INSTALL & USE

- G. Ensure the adjuster is behind the front edge of the car's seat back or headrest.

**! IMPORTANT:**

**The harness straps must always be fitted on each side of the child's neck.**

When not in use, the Defenda™ Harness may be flipped onto the parcel shelf or disconnected from the anchor fitting and stored. If a Gated Slide is used it must be removed so an adult can use the seating position.

**! WARNING:**

**DO NOT LEAVE CHILDREN UNATTENDED IN THE CAR.**

**The lap portion of the belt must be adjusted firmly first, and then the harness, so that the belt is not lifted off the child's lap when the harness is adjusted. The shoulder straps do not need to be tight.**

- H. When using an Extension strap the adjuster must be behind the seat back and away from your child's head. If this is not the case either use a shorter Extension strap or remove the Extension Strap.

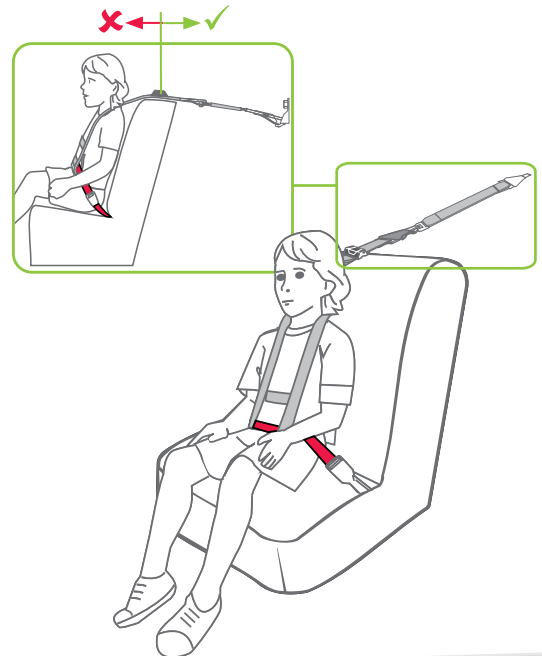

WITH CAR'S SEAT

WITH CAR'S SEAT

# HOW TO INSTALL & USE

# CORRECT FITMENT

## TO REMOVE CHILD FROM THE HARNESS

To remove the child from the car, release the seatbelt buckle and then take the Harness and seatbelt over the child's head. The Harness can be refitted the next time without adjusting the Harness. Review the fitting from time to time but always ensure the Harness is correctly adjusted.

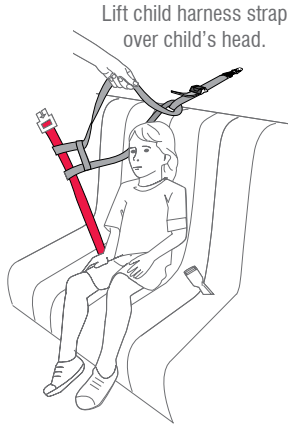

## TO REMOVE HARNESS FROM VEHICLE

- A. Feed seat belt out through Child Harness.
- B. Disconnect the attachment clip from the car.
- C. Remove the Gated Slide, if used, from the seat belt so an adult may use the seatbelt as a lap-sash seatbelt.

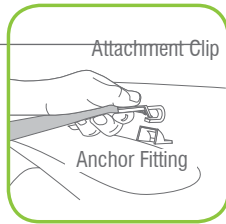

## Defenda™ HARNESS AND BOOSTER SEAT

If the Booster Seat is fitted with a Lap Belt Positioning Device, such as SLIDEGUARD™ clip, always use it. It will prevent the child slumping or the seatbelt riding up on to the child's abdomen.

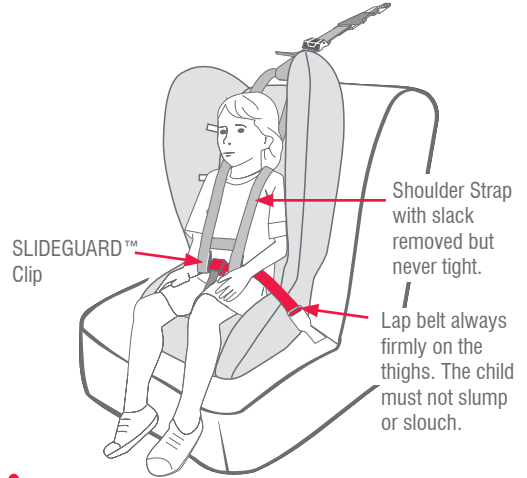

**CAUTION:** ALWAYS FOLLOW THE BOOSTER SEAT INSTRUCTIONS AND LABELLING. FOLLOW SEAT BELT PATHS.

## Defenda™ HARNESS AND CAR'S SEAT BELT

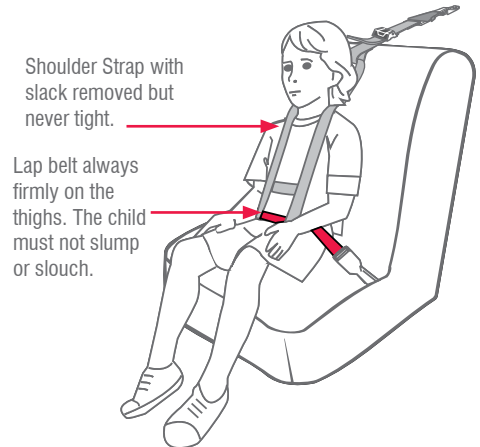

**IMPORTANT:** The harness straps must always be fitted on each side of the child's neck.

WITH CAR'S SEAT

## NEXT TYPE OF RESTRAINT THAT CAN BE USED IN THE CAR FOR YOUR CHILD.

If you are using a booster seat and the child's shoulders have reached the top height marker then you can use just the child harness and the lap only seat belt.

When the child reaches 36kg then they need to discontinue using the child harness, and use just the car's seat belt.

When using the child harness on the car's seat discontinue using the harness when the child's shoulders reach the top of the car's seat or the car's headrest.

**EACH REGION HAS ROAD RULES THAT REQUIRE A CHILD TO BE PROPERLY RESTRAINED. ALWAYS FOLLOW THE RULES.**

If you have outgrown the booster seat then you can use a Child Harness and car's lap only seat belt



If the child is over 36kg then they can just use the car's seat belt. The seat belt must be correctly fitted.

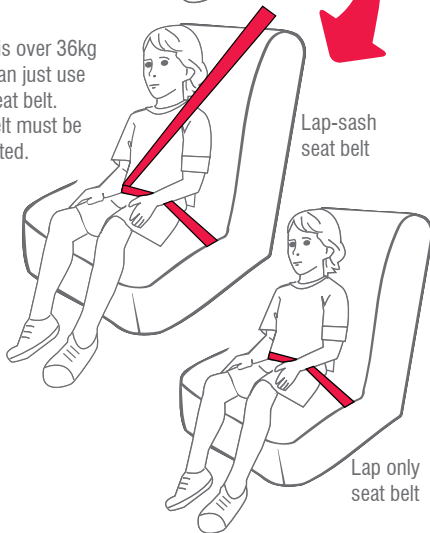

**NOTE:** Lap belt offers less retention in a crash than a Lap-sash seatbelt.

Consult the vehicle owner's handbook for location of anchorage fittings or anchorage points and the possible use of spacers. Some vehicles may have an anchor fitting fitted by the vehicle manufacturer. If anchorage points cannot be found refer to car manufacturer or local child restraint fitting station or traffic authority for optimum position of anchorage point and the use of spacers.

## UPPER ANCHORAGE STRAP

**! IMPORTANT:**

**THE ATTACHMENT CLIP COVER MUST ALWAYS BE USED AS IT PREVENTS THE RISK OF INCORRECT FITMENT OF THE ATTACHMENT CLIP TO THE ANCHOR FITTING. ALWAYS ENSURE THAT THE ATTACHMENT CLIP IS CORRECTLY ENGAGED TO THE ANCHOR FITTING AND NOT HOOKED OR FITTED TO ANY OTHER OBJECT BEFORE EACH USE OF THE RESTRAINT. THIS IS ESPECIALLY IMPORTANT IN VEHICLES SUCH AS STATION WAGONS, VANS, HATCH BACKS OR VEHICLES WITHOUT A FIXED PARCEL SHELF, SINCE THE ANCHOR POINT IS USUALLY NOT VISIBLE.**

### IMPORTANT INSTALLATION NOTE:

In some vehicles the anchor fitting in the rear vertical panel can only be installed in one way. Please refer to vehicle owner's handbook or a child restraint fitting station for correct method.

Extension Strap distance to be measured.  
 Length 300mm (Use Safe-n-Sound part 0035 or equivalent)  
 Length 600mm (Use Safe-n-Sound part 0036 or equivalent)  
 Available from all major child restraint retailers.

The shaded areas of this diagram illustrate the possible locations of the anchor fitting. Within each shaded area is an anchor fitting showing the correct way to install the fitting. Ensure the anchor fitting is aligned as illustrated unless stated otherwise in the vehicle owner's handbook.

# PRE-INSTALLATION ANCHOR FITTING

## IF THE CAR IS FITTED WITH CHILD RESTRAINT ANCHORAGE POINT

Locate the anchorage point behind the rear seating position. (consult the car owners handbook for the location of the anchorage point). The anchorage point should be directly behind and central to the restraint. Remove thread plug from the parcel shelf/floor/roof, etc. and install anchor bolt and fitting as shown in Fig.1.

**CAUTION: DO NOT OVERTIGHTEN ANCHOR BOLT. OVERTIGHTENING MAY FRACTURE OR BREAK BOLT. MAXIMUM TORQUE IS 20 Nm (14.75 ft.lb.)**

Note: Minimum of five full turns of anchor bolt is required before tightening force is applied.



## IF THE CAR IS NOT FITTED WITH CHILD RESTRAINT ANCHORAGE POINTS

**For Sedans only** - Drill 9mm diameter hole in the parcel shelf on the centre line of the seating position as shown in Fig.3. Before drilling the hole, check the underside for accessibility. Install the anchor bolt as shown in Fig.2.

**For vehicles other than Sedans** - In Australia, consult your nearest child restraint fitting station or traffic authority for vehicle inspection to find the best, correct position for the placement of the anchorage point, and for the correct attachment bolt length and use of spacers. In New Zealand, consult the agent for the vehicle.

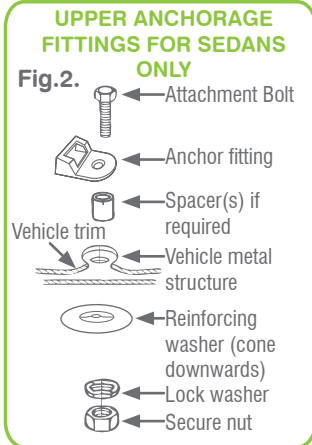

# PRE-INSTALLATION ANCHOR FITTING

Note to Queensland purchasers: The installation of anchorage points must be approved by authorised officers appointed by Queensland Transport. Authorised officers can be sourced from all Queensland Transport Customer Service and Queensland Ambulance Service Centres.

ONLY USE A 5/16 UNC GRADE 5 BOLT. IF THE BOLT IS NOT THE CORRECT LENGTH THE CAR MANUFACTURER'S HANDBOOK CAN PROVIDE ADVICE ON THE CORRECT LENGTH BOLT.



Note: Marking on the top of a Grade 5 Bolt.

## **WARNING:**

**CHILD RESTRAINTS MUST NOT BE ATTACHED TO UNSOUND METAL OR TO WOOD, OR SYNTHETIC STRUCTURES. WHEN DRILLING 9 MM HOLE DO NOT DRILL THROUGH FUEL LINES, FUEL TANKS, ELECTRICAL WIRING, OR RADIO SPEAKERS. WEBBING STRAPS MUST BE PROTECTED FROM SHARP CORNERS AND EDGES. THE ANCHOR FITTING MUST BE USED ONLY AS DESCRIBED ABOVE. IT MUST NOT BE HOOKED ONTO ANY OTHER OBJECT.**

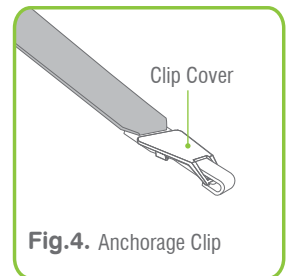
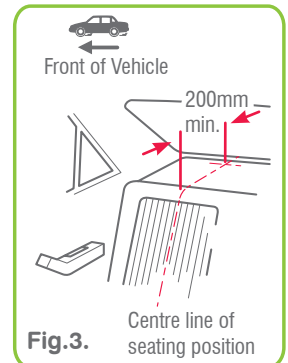

## UPPER ANCHORAGE STRAP

### **IMPORTANT:**

**THE ATTACHMENT CLIP COVER (SEE FIGURE 4 ON THE PREVIOUS PAGE) MUST ALWAYS BE USED AS IT PREVENTS THE RISK OF INCORRECT FITMENT OF THE ATTACHMENT CLIP TO THE ANCHOR FITTING. ALWAYS ENSURE THAT THE ATTACHMENT CLIP IS CORRECTLY ENGAGED TO THE ANCHOR FITTING AND NOT HOOKED OR FITTED TO ANY OTHER OBJECT BEFORE EACH USE OF THE RESTRAINT. THIS IS ESPECIALLY IMPORTANT IN VEHICLES SUCH AS STATION WAGONS, VANS, HATCH BACKS OR VEHICLES WITHOUT A FIXED PARCEL SHELF, SINCE THE ANCHOR POINT IS USUALLY NOT VISIBLE.**

The restraint strap & Attachment Clip may be damaged or disconnected by unsecured vehicle contents. To ensure a secure engagement, before each use of the restraint follow this procedure:

- A. Secure or remove any vehicle contents.
- B. Remove slack from the Upper Anchorage Strap and ensure that strap is not twisted. The strap does not need to be tight as it may lift the seat belt off the child's thighs.
- C. Make sure the Attachment Clip is correctly engaged.

## VEHICLE INSTALLATION ACCESSORIES

(Available from retailers of Safe-n-Sound products)

**EXTRA ANCHOR KITS:** Are available if using the restraint in additional vehicles. Re-order number: 0038

**EXTENSION STRAPS:** May be required for vehicles without a fixed parcel shelf. Re-order number: 0035 (length 300mm) 0036 (length 600mm).

**GATED 3-BAR SLIDE:** For converting lap-sash seat belt to lap belt. Re-order number: 0215 (one gated slide is provided with this Harness).

## MAINTENANCE

Ensure all stitching and webbing are not fraying. Clean webbing with damp cloth and allow to dry.

Check the adjuster is operating correctly and locking onto the strap.

If your restraint has been involved in a severe crash, you should destroy the restraint even if no damage is obvious. Some insurance companies offer vehicle insurance which covers or partially covers the replacement of your child restraint. Contact your insurance company for further details.

Your insurance company may require you to keep the child restraint for assessment, **but do not use the child restraint after a severe crash**. To assist you in making an accident insurance claim cut the following statement and include it with your claim.

### **NOTICE TO INSURANCE COMPANY CHILD RESTRAINT INVOLVED IN AN ACCIDENT**

All Safe-n-Sound child restraints are manufactured to Australian/New Zealand Standards AS/NZS1754-2010 which requires us to advise users of child restraints to "Destroy the entire restraint if it has been in use in a severe crash, even if no damage is obvious". The joint Australian/New Zealand Standards committee CS/85, advise that this statement applies whether a child was in the child restraint or not. We consider a "severe crash" as being one where the main body structure of the vehicle is distorted.

There is no method of determining if the restraint has been damaged and we concur with the Australian/New Zealand Standards in recommending destruction of the child restraint.

This notice is to advise you of the requirements of the Australian/New Zealand Standards and our obligation in complying with the standards.

Please assist the owner of this restraint in their claim.

### **Britax Childcare Pty. Ltd.**

(Incorporated in Victoria)  
A.B.N 55 006 773 600

#### **Head office and registered address:**

99 Derby Road Sunshine Victoria 3020

PO Box 147 Sunshine Victoria 3020

**Telephone:** 1300 303 330

**www.britax.com.au**

#### **New Zealand Office**

Britax Childcare NZ Limited.

**Telephone:** 0508 688 822

**www.britax.com.nz**



## AUSTRALIA

Britax Childcare Pty. Ltd.  
A.B.N 55 006 773 600

### **Head office and registered address**

99 Derby Road, Sunshine, Victoria 3020.  
PO Box 147 Sunshine, Victoria 3020.

**Customer Service** 1300 303 330

**Email** [au-custserv@britax.com](mailto:au-custserv@britax.com)

**www.britax.com.au**

## NEW ZEALAND

Britax Childcare (NZ) Ltd.

**Customer Service** 0508 688 822

**Email** [nz-custserv@britax.com](mailto:nz-custserv@britax.com)

**www.britax.co.nz**

## INTERNATIONAL ENQUIRIES

---

Contact your local Distributor.

The Safe-n-Sound, Defenda and SLIDEGUARD trademarks are the property of Britax Childcare Pty. Ltd. (Australia).

The Britax trademark is the property of Britax Excelsior Limited (UK).

We reserve the right to alter this product without notice.

© 2005-2011 Britax Childcare Pty. Ltd.



# Defenda™ Child Harness

Series Number: 217/2010

The Defenda™ Harness can be used with some Booster Seats and Booster Cushions that are suitable for use with this Series 217/2010 Child Harness.

To be used only in a forward facing position.

For children aged approximately 4 to 7 years of age, the restraint should be used with a compatible booster seat and seatbelt.

For children aged approximately 7 to 10 years of age, the restraint should be used either with a compatible booster seat and seatbelt, or on a vehicle seat with a lap only seatbelt.

It is not recommended that this restraint be used on a vehicle seat with a lap-sash seatbelt.

Suitable for children up to 36kg. Suitable for use with a child on the car's seat until the child's shoulders are above the top of the car's seat back or headrest.

**TO BE USED WITH A LAP-SASH OR LAP ONLY SEAT BELT IN THE BACK OF MOST CARS WITH FORWARD-FACING SEATS.**

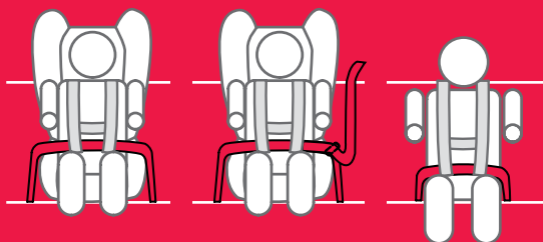

Lap Only belt

Lap/Sash belt

Lap Only belt

## SUITABILITY

This Child Harness is not suitable for Booster Seats or Convertible Booster Seats that have Upper Anchorage Straps (Tether Straps).

**THIS RESTRAINT IS NOT SUITABLE FOR USE WHERE THE ANCHORAGE STRAP MAY FALL INTO A SPLIT IN THE SEAT BACK (E.G. HATCHBACK OR WAGON).**

**Do not use** on any vehicle seat which faces sideways or rearwards.

**THIS RESTRAINT MUST BE ATTACHED TO A CHILD RESTRAINT ANCHORAGE POINT IN THE CAR. REFER TO CAR OWNER'S HANDBOOK FOR LOCATION OF ANCHORAGE POINTS. REFER TO A CHILD RESTRAINT FITTING STATION IF NO ANCHORAGE POINTS ARE IN THE MOTOR CAR.**

No child restraint can guarantee absolute protection from injury in every crash. However, to ensure that your child gets all the protection provided by the Defenda™ Harness read and follow the enclosed instructions exactly.

Additional Extension Straps may be required for vehicles without a fixed parcel shelf.

Re-order Numbers: 0035 (length 300 mm) or 0036 (length 600 mm) Spacers, if required, they are included in this package.

This package does not include an adult seat belt.