

Steelcraft™ Agile

Twin Stroller

BRITAX CHILDCARE PTY. LTD A Britax International company.
(Incorporated in Victoria) A.B.N. 55 006 773 600
99 Derby Road, Sunshine, Victoria 3020, Australia
Phone: (03) 9288 7288 Fax: (03) 9311 5798

CUSTOMER SERVICE
1300 303 330 - Australia 0508 688 822 - New Zealand

Due to our continuing program of development, Britax reserves the right to alter the specifications, color or design without any further notice.

The Steelcraft trademark is the property of Britax Childcare Pty.Ltd - Australia.

The Britax trademark is the property of Britax Excelsior Limited - UK.

Visit the Britax website at: www.britax.com.au or email us at au-custserv@britax.com

Due to the variations in the style and design of our products the illustrations used in this instruction booklet are generic.

This product is designed to comply with Australian and New Zealand standard AS/NZS2088 "Prams and Strollers - Safety Requirements."

©2010 Copyright Britax Childcare Pty. Ltd. Australia

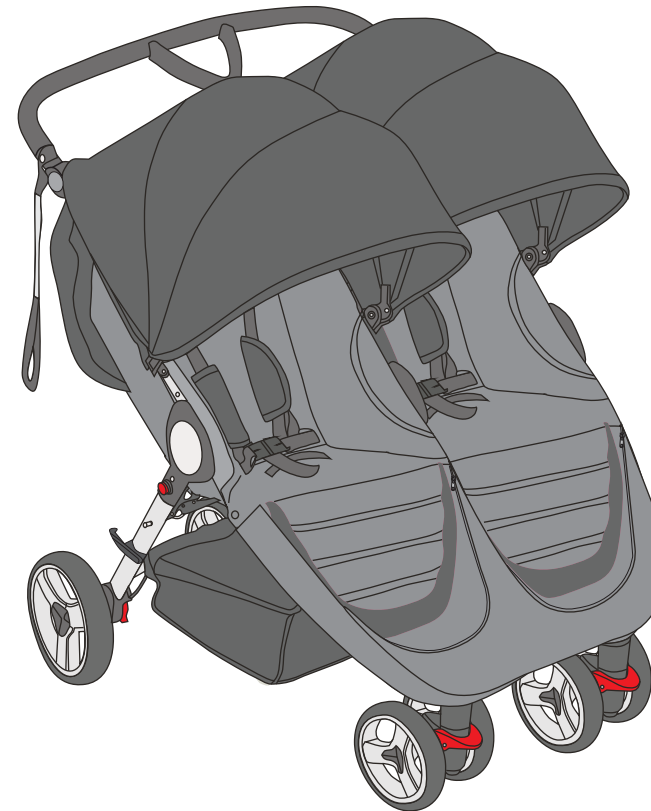

SUITABLE FOR USE WITH THE STEELCRAFT INFANT CARRIER (SOLD SEPARATELY)

IMPORTANT: KEEP THIS BOOKLET IN A SAFE PLACE FOR FUTURE REFERENCE.

Steelcraft™

Steelcraft™

Series No. SH819

WARNINGS

RETAIN FOR FUTURE REFERENCE.
READ ALL INSTRUCTIONS CAREFULLY BEFORE ASSEMBLY AND USE OF THIS STROLLER. ALWAYS FOLLOW THE INSTRUCTIONS. THE CORRECT USE AND MAINTENANCE OF THIS PRODUCT IS ESSENTIAL.

WARNINGS: TO AVOID INJURY OR DEATH:

ALWAYS APPLY THE BRAKES WHENEVER THE STROLLER IS STATIONARY.

- FOLLOW THE MANUFACTURERS INSTRUCTIONS.
- DO NOT LEAVE CHILDREN UNATTENDED.
- SECURE THE CHILD IN THE HARNESS AT ALL TIMES.
- DO NOT CARRY EXTRA CHILDREN OR BAGS ON THIS STROLLER.
- MAKE SURE CHILDREN ARE CLEAR OF ANY MOVING PARTS IF YOU ADJUST THE STROLLER.
- USE THE HARNESS AT ALL TIMES.
- WHEN NOT IN USE DISCONNECT SHOULDER STRAPS FROM THE WAIST STRAPS AND BUCKLE TO PREVENT STRANGULATION.
- Check that all safety locks are engaged before placing a child in the stroller.
- Ensure your child is secured with a correctly adjusted safety harness.
- Use the tether strap to prevent the stroller from rolling away.
- Never let go of the stroller when parked on an incline because it may slide or tip over. Always park on a flat surface.
- Remove the child from the stroller before going up or down stairs or escalators.

CARE AND MAINTENANCE

- To prolong the life of your stroller and accessories keep it clean and do not leave it in the direct sunlight or in the car boot for extended periods of time.
- Removable fabric covers and trims may be cleaned using warm water with a household soap or mild detergent. Allow it to dry fully, preferably away from the direct sunlight.
- Non removable fabric covers and trims may be spot cleaned using a damp sponge with soap or a mild detergent. Allow it to dry completely before folding or storing it away.
- In some climates the covers and trims may be affected by mould and mildew. To help prevent this occurring, do not fold or store the product if it is damp or wet. Always store the product in a well ventilated area.
- When using your stroller at the beach - completely clean your stroller afterwards to remove the sand and salt from the mechanisms and wheel assembly. Sand and salt will cause premature wear and corrosion.
- If there are compression marks on the tyres - Use a domestic hair dryer to gently warm (DO NOT OVERHEAT) the tyre and the compression marks should slowly disappear.
- Always check parts regularly for tightness of screws, nuts, and other fasteners - tighten if required. To maintain the safety of your nursery product, seek prompt repairs for bent, torn, worn or broken parts.

THIS PRODUCT IS NOT INTENDED FOR COMMERCIAL USE.

16. TO RELEASE THE INFANT CARRIER (Cont)

- C Lift and remove the Infant Carrier away from the stroller.

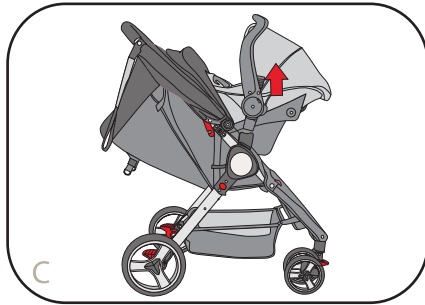

- D To remove the adaptors, press the red button in on the inside of the adaptor and pull the adaptor up.

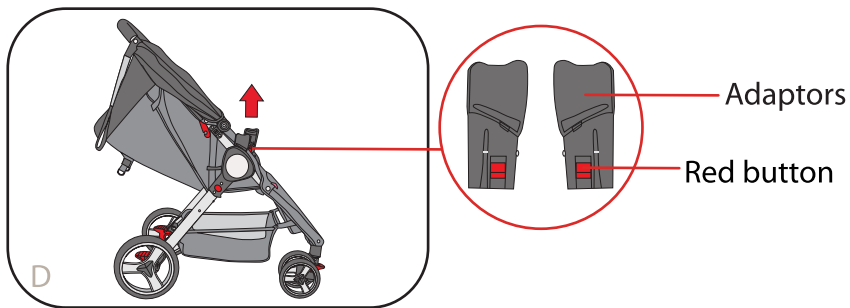

WARNINGS CONTINUED

WARNINGS

- Do not allow children to stand on the seat.
- Do not hang bags or goods from the handle as this could cause the stroller to tip over.
- To prevent the risk of the stroller catching fire, do not park it near an exposed heat source such as a radiator, an open fire or a barbecue, etc.
- Do not run while using this product.
- Always lock swivel wheels when on rough surfaces as this will help eliminate wheel wobble.
- Always raise the leg support (where fitted) to its highest position when transporting a baby. This will reduce the risk of the baby falling out through the front of the stroller.
- It is unsafe to use accessories other than those tested and approved by Britax. For maximum safety only use accessories designed for this stroller.
- Do not place more than 2kg in each basket or 1kg in each Canopy pocket (if supplied)
- The maximum weight of the child in each seat using this product is not to exceed 20kg for the Stroller or 9kg for the Infant Carrier.

FOR WARNINGS ON ACCESSORIES - REFER TO THEIR INDIVIDUAL SECTIONS IN THIS BOOK. THE MAXIMUM WEIGHT VARIES FOR EACH ACCESSORY.

IMPORTANT

The upright positions are not suitable for use with children less than six months old. The lowest recline position should be used to transport babies, and the backrest can be adjusted to a more upright position as the child grows older and is able to support its head without assistance.

SAFETY WARNING

The sun is very strong. **DO NOT LEAVE YOUR CHILD EXPOSED TO THE SUN.** The canopy or hood on this product will not give your child total protection from the harmful rays of the sun.

16. TO RELEASE THE INFANT CARRIER

- A To remove the Infant Carrier, squeeze both handle latches in to release the locks. The indicator will now be RED.

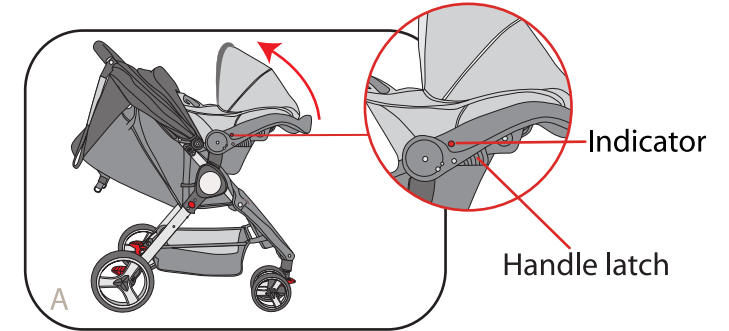

- B Continue to rotate the handle forward until it returns to the upright position. Release the latches, the indicator should now be GREEN.

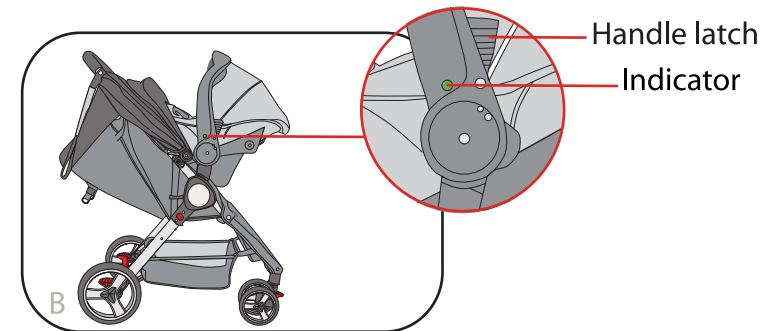

15. TO INSTALL THE INFANT CARRIER (Cont)

- E Release the handle latches. Then with one hand holding the front of the Infant Carrier, push the Infant Carrier handle all the way down until you hear it lock into the adaptors. The handle indicator should now be GREEN and the Infant Carrier should be locked into the adaptors. If the indicator is RED the Infant Carrier handle is not in the locked position, repeat step D.

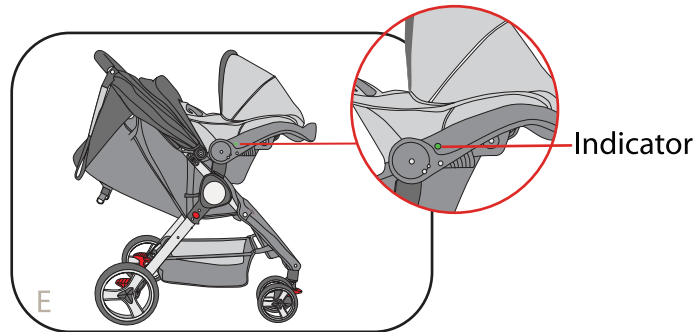

IMPORTANT: Ensure that the Infant Carrier is locked into place by pulling up on both sides. Do not use the Infant Carrier if it is not correctly installed.

Please Note: The Infant carrier has been fitted with a hood when using the stroller. The hood can also be used in the car. Refer to the Infant Carrier instructions regarding placing and securing your baby in the Infant Carrier.

PARTS LIST

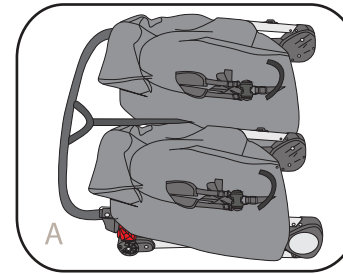

A 1 x Stroller Frame

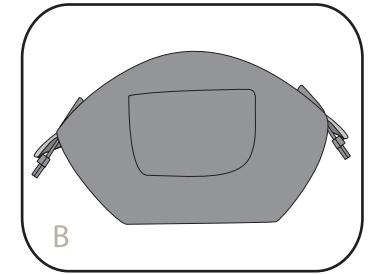

B 2 x Canopies

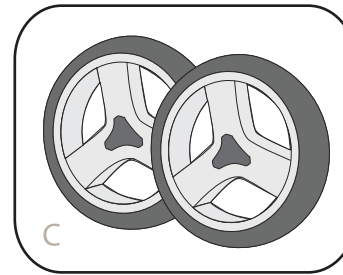

C 2 x Rear Wheels

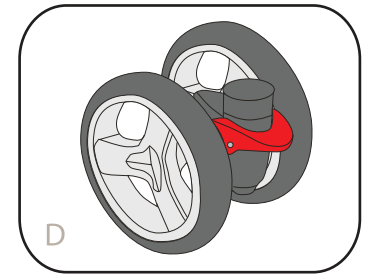

D 2 x Front Wheel sets

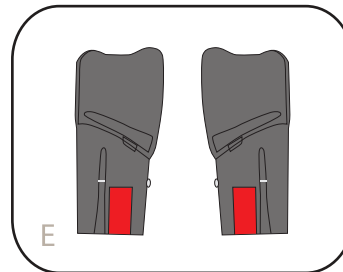

E 2 x Infant Carrier Adaptors

ASSEMBLED STROLLER - PARTS LIST

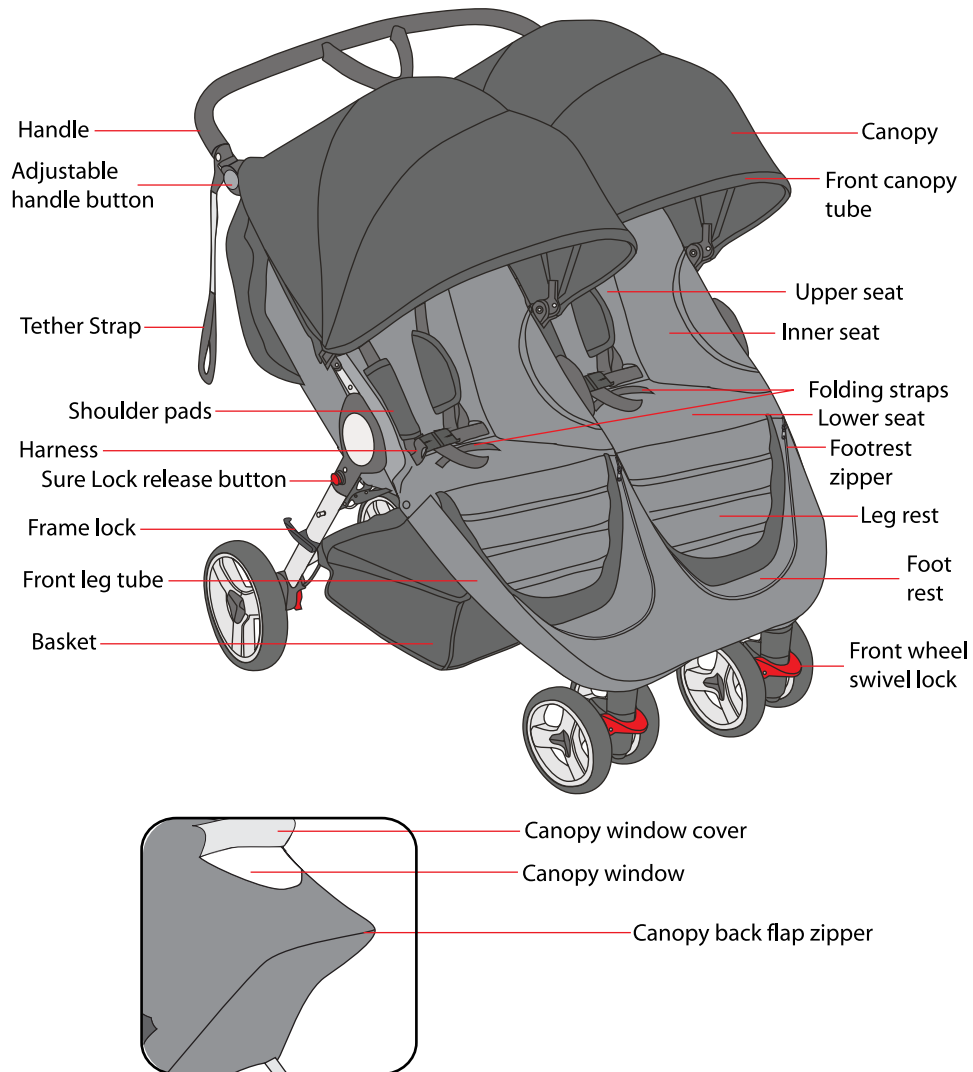

15. TO INSTALL THE INFANT CARRIER (Cont)

- C Lower the Infant Carrier into the adaptors. Press down firmly on both sides.



- D The Infant Carrier now needs to be locked securely into the adaptors. Squeeze in and hold the latches on either side of the handle, rotate the handle backwards. The GREEN indicator will now turn to RED.

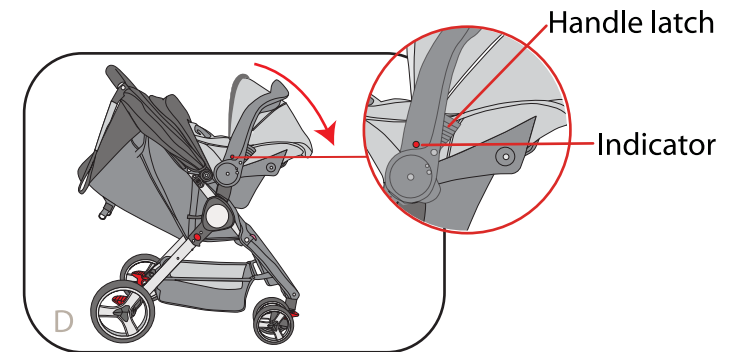

15. TO INSTALL THE INFANT CARRIER (Sold Separately)

- A Stand in front of the stroller and pull the fabric back from the sides of the stroller to expose the stroller hinge. Take one Infant Carrier adaptor at a time and insert the adaptor into the stroller hinge. Push on the adaptor until you hear a 'click' which indicates the adaptor has locked in. Pull up on each adaptor to check they have fully locked in.

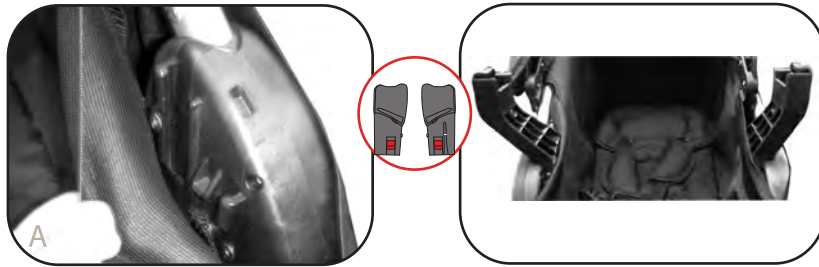

Please Note: Fit adaptors standing in front of the stroller.

- B Face the feet end of the Infant Carrier towards the stroller backrest. With the Infant Carrier handle in the upright position locate the Infant Carrier handle mouldings over the adaptors on either side. Notice the indicator is GREEN

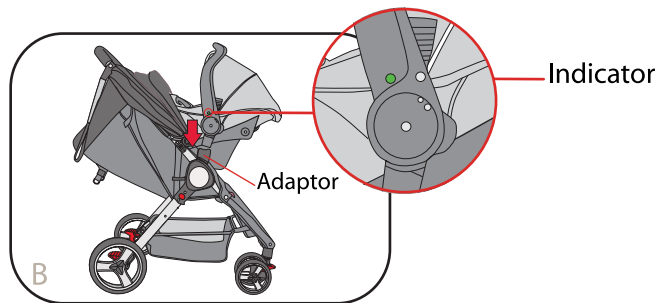

01. TO OPEN THE STROLLER

- A Release the storage latch (1) located on the rear leg. Open the frame as shown by the arrows (2) until you hear a 'click' which indicates the frame is fully opened and locked.

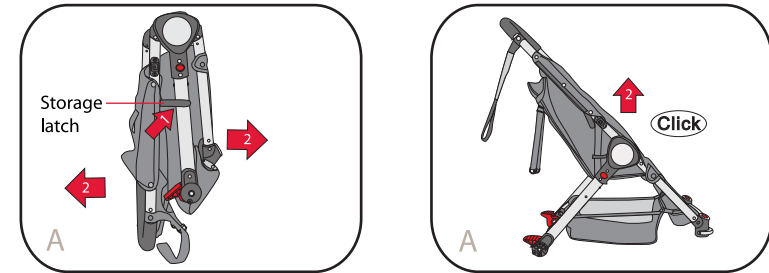

02. TO ASSEMBLE AND REMOVE THE FRONT SWIVEL WHEELS

- A To assemble the front swivel wheel assemblies, insert the swivel wheel assembly and push it into the wheel mouldings until you hear a 'click' which indicates the wheel is locked in. Check the wheel assembly is fully locked by pulling against it.
- B To remove the front swivel wheel assembly, locate and press in the Black button behind the wheel moulding.

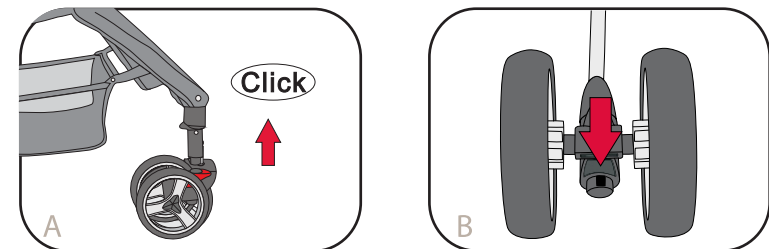

03. TO FIT AND REMOVE THE REAR WHEELS

- A To fit the rear wheels, insert each wheel axle into the moulding and push in until locked. You should hear a 'click' which indicates the wheel has locked in. Pull on the wheel to make sure it is engaged. Repeat the process if not locked in.
- B To remove the wheels, pull the metal latch downwards on the underneath of the brake moulding to release the wheel, and then pull the wheel off.

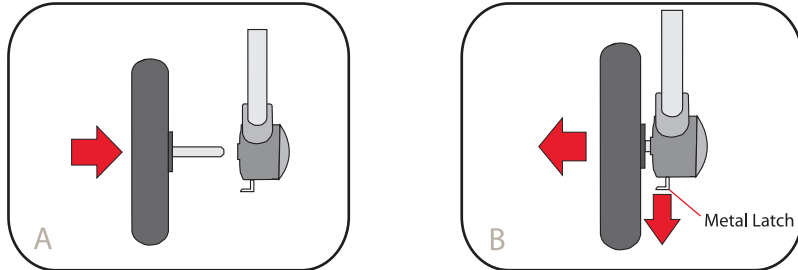

04. TO USE THE SWIVEL WHEELS

- A Press the swivel lock down to lock the swivel wheels.
Push the swivel wheel lock up to allow the wheels to swivel.
- Note: Always lock the swivel wheels when using the stroller on rough surfaces as it will minimise wheel wobble.**

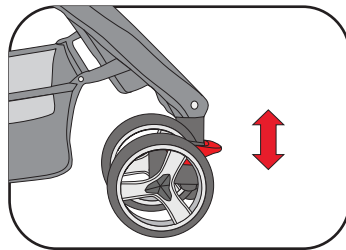

15. TO INSTALL THE INFANT CARRIER (Sold Separately)

WARNINGS

- THE STEELCRAFT INFANT CARRIER IS THE ONLY INFANT CARRIER DESIGNED TO FIT THIS STROLLER.
- THE INFANT CARRIER MUST BE CORRECTLY FITTED AND LOCKED ONTO THE STROLLER USING THE SUPPLIED ADAPTORS.
- THE INFANT CARRIER MUST ONLY BE USED IN THE REARWARD FACING POSITION, FITTED TO THE STROLLER FACING TOWARD THE STROLLER HANDLE.
- SECURE THE CHILD IN THE HARNESS AT ALL TIMES.
- DO NOT LEAVE THE CHILD IN THE INFANT CARRIER FOR EXTENDED PERIODS.
- THE INFANT CARRIER IS DESIGNED TO PROVIDE MOBILITY OUTSIDE OF THE CAR BUT IT SHOULD NOT BE USED INSTEAD OF AN APPROPRIATE COT.
- THE INFANT CARRIER MUST BE REMOVED FROM THE FRAME BEFORE FOLDING.
- THE MAXIMUM WEIGHT OF THE CHILD USING THIS PRODUCT IS NOT TO EXCEED 9kg.

Please Note: These Instructions are for installing and removing the Infant Carrier on the stroller only.

For installing and proper care of the Infant Carrier in the car please follow the Instruction book that is included with the Infant Carrier.

14. TO FOLD THE STROLLER (Cont)

- B2 Move to the front of the stroller and with both hands pull up on both folding straps (2) as shown by the arrow. The stroller will now fold.

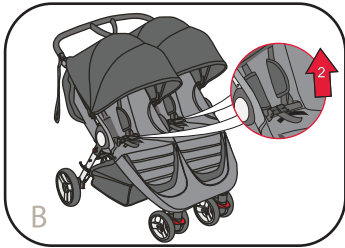

- C Ensure the frame is secured with the storage latch. Carry the stroller by the folding strap or by the frame.

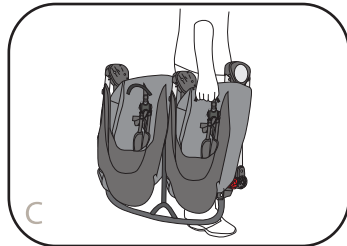

05. TO ATTACH AND USE THE CANOPIES

- A1 To attach the canopies, insert the canopy mouldings into the frame mouldings until they connect together. The back flap of the canopy can be attached or removed from the main canopy with the zipper attachment.

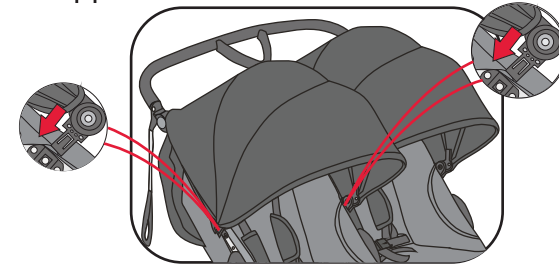

- A2 Attach the snaps located on the straps on the sides of each canopy to the top of the outer handle tubes, then fold the strap up under the canopy back flap and secure strap with hook and loop to the underneath of the canopy.



05. TO ATTACH AND USE THE CANOPIES (Cont)

- A3 Thread each loop strip through the guide moulding located on the middle handle tube. Then attach the loop strip to the hook strip underneath the canopy.

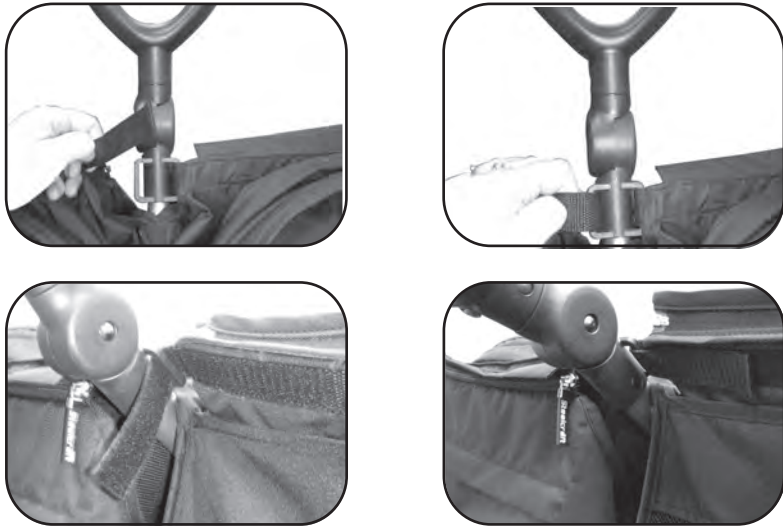

- A4 Attach the hook square on the inside of the canopy backflap to the loop strip on the side of the stroller.



14. TO FOLD THE STROLLER

- A To prevent the canopy back flaps from dragging on the ground when the stroller is folded, either remove the back flaps by opening the zippers at the top of the back flaps, then close the canopies, or push each canopy back flap into small mesh pocket on each backrest.

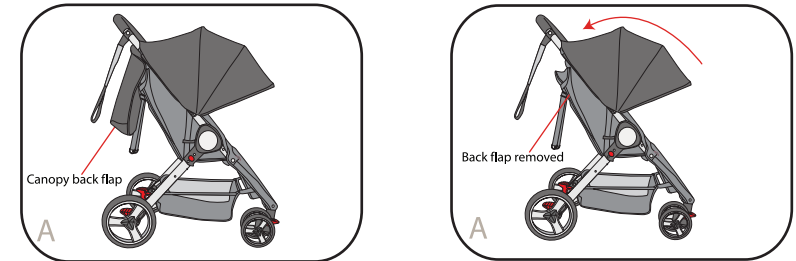

- B1 Rotate the handle in towards the canopy before you fold the stroller (See page 19) as this will assist in preventing damage to the stroller handle when folding. Press in the RED Sure Lock release button (1) located on the right hand side of the stroller.

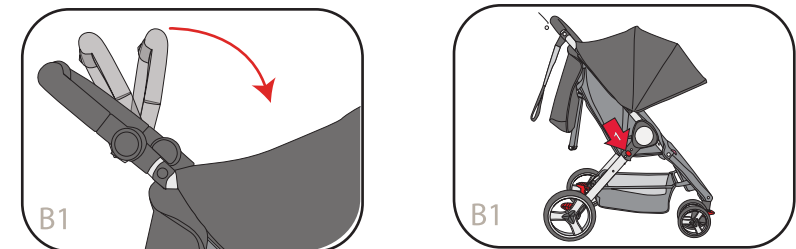

13. TO USE THE STROLLER

- With your hand through the wrist tether strap loop, push the stroller holding the handle.
- The stroller can be steered in the desired direction - allowing the front wheels to swivel will make this easier.
- The front wheels may wobble or oscillate when walking fast.
- Locking the front swivel wheels will stop this.
- The stroller can be taken up kerbs by either pressing down on the handles and raising the front wheels or turning the stroller around and pulling the stroller up the kerb.
- Caution is required when pushing the stroller on a steep slope as the stroller may become unstable. Always hold the handles firmly.
- Whenever you stop, always apply the brakes before you leave the stroller.

05. TO ATTACH AND USE THE CANOPIES (Cont)

- A5 Attach the hook strip on the inside edge of the canopy to the loop strip on the side of the stroller.



- B To remove the canopy, press in the buttons on the canopy mouldings and pull out of the frame mouldings.

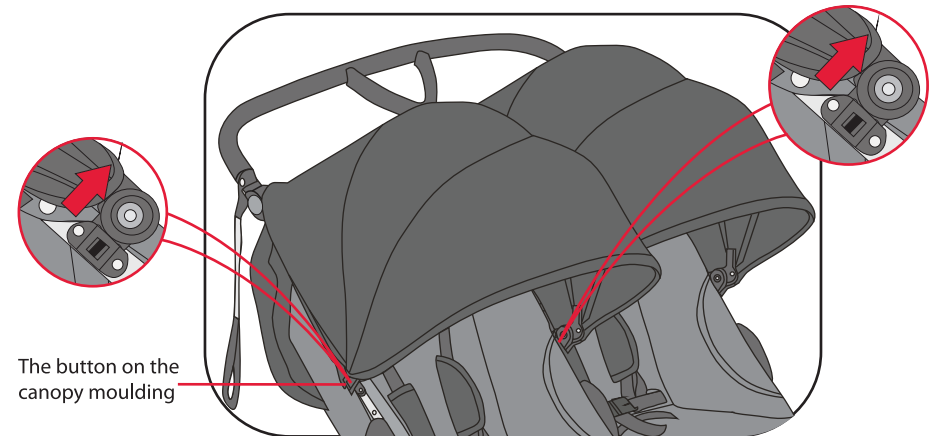

05. TO ATTACH AND USE THE CANOPIES (Cont)

- C To adjust the canopy, open by pulling canopy forward, or close by pushing canopy backward.

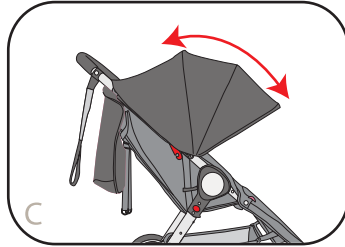

- D To open the canopy window lift the canopy window flap away from the canopy.

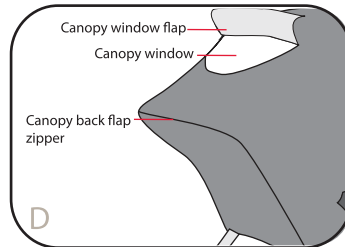

- E For additional air circulation the back flap of each canopy can be removed by opening the zipper. To reattach the back flap to the main canopy secure with the zipper.



12. TO USE THE STORAGE BASKET

- A When the stroller seats are in the full recline position it may be difficult for you to access the storage basket from the rear of the stroller. For easier access undo the zippers on the leg rest to access the storage baskets from the front of the stroller.

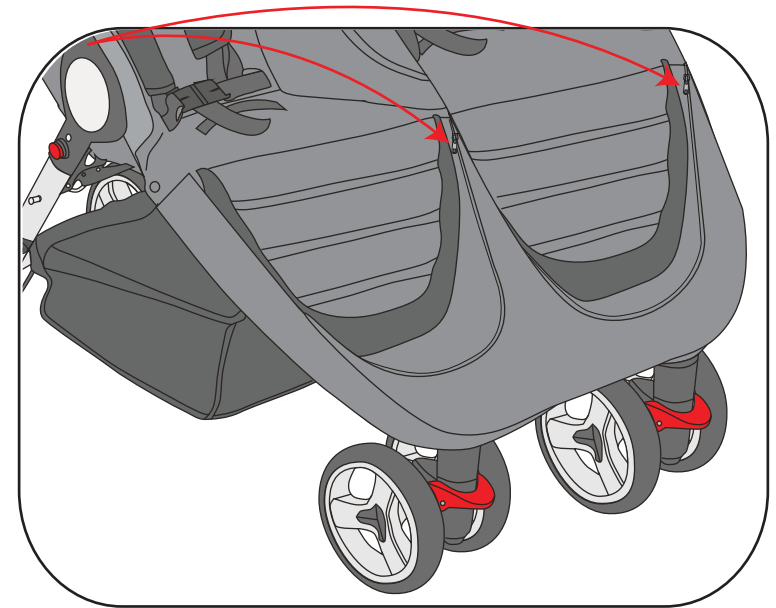

11. TO FIT THE RAIN COVER

- A Place the rain cover over extended canopy as shown. To secure the rain cover, attach the hook and loop straps on the front of the rain cover around the wheel mouldings above the swivel wheel lock then attach the hook and loop strips on the sides of the rain cover.

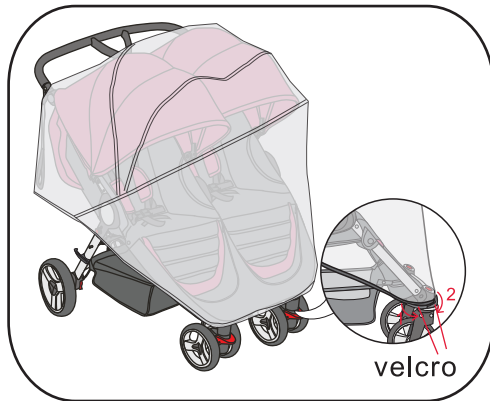

06. TO ADJUST THE BACKREST

WARNING: ENSURE THAT YOUR CHILD'S LIMBS ARE IN THE CENTRE OF THE SEAT AND SUPPORT YOUR CHILD'S WEIGHT WHEN USING THE BACKREST.

- A To raise each backrest, hold the main adjuster moulding in one hand, then grasp the plastic rings fixed to the adjuster straps with the other hand. Push up on the main adjuster moulding at the same time pull the adjuster strap to the desired position.
- B To lower each backrest, support the backrest with one hand and with the other hand pull down the on the backrest adjuster button and lower the backrest to the desired position.

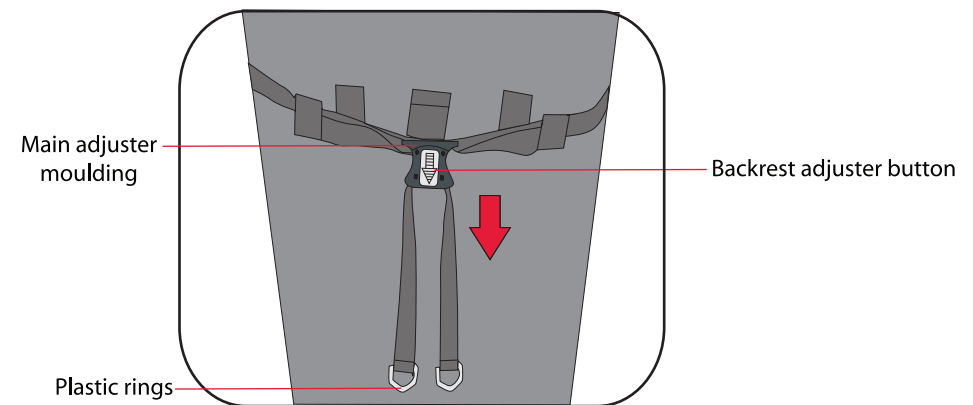

07. TO USE THE BRAKES

WARNING: ALWAYS APPLY THE BRAKES WHEN THE STROLLER IS NOT MOVING. THE STROLLER MAY ROLL AWAY EVEN IF LEFT UNATTENDED FOR A FEW MOMENTS.

- A To lock the rear wheels, press down on the brake pedal. Check that the brakes have locked by trying to push the stroller forward. If not locked, repeat this step.
- B To release the brakes, push up on the brake pedal.

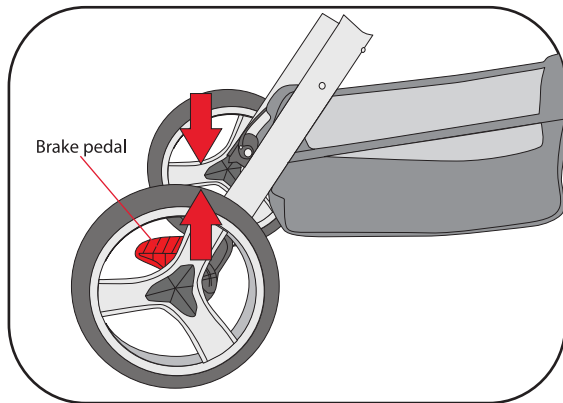

09. TO ADJUST THE PIVOTAL HANDLE

- A There is a handle adjusting button on the inside of each handle moulding. Press both adjusting buttons in together and rotate the handle up or down to the desired position, then release both buttons.

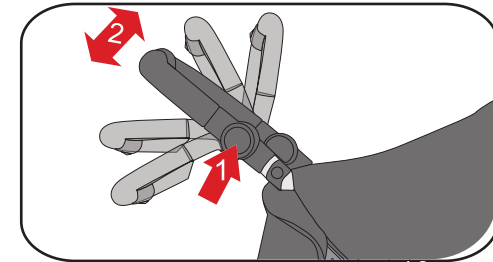

10. TO USE THE TETHER STRAP

WARNING: USE THE TETHER STRAP TO PREVENT THE STROLLER ROLLING AWAY.

- A A wrist tether strap is provided on the handle grip. Slide your hand through the tether strap loop whenever you use the stroller. Only remove your hand from the tether strap loop when the brakes have been applied to the stroller wheels.



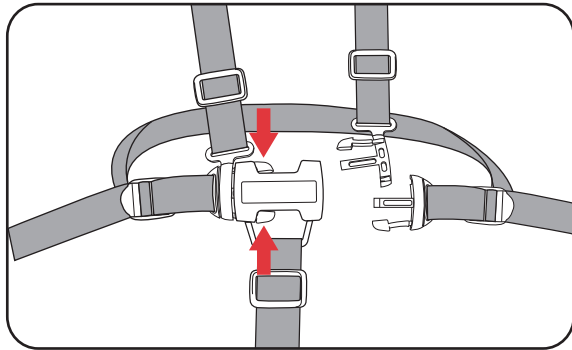

F To release the buckle. Squeeze the top and buckle tongues together with enough pressure so the buckle tongues can release from the buckle housing.

G The stroller seat has *2 or 3 sets of harness slots at different heights to accommodate the child. To change the shoulder harness height, push the shoulder harness tongue out of the current harness slot and through the back of the seat.

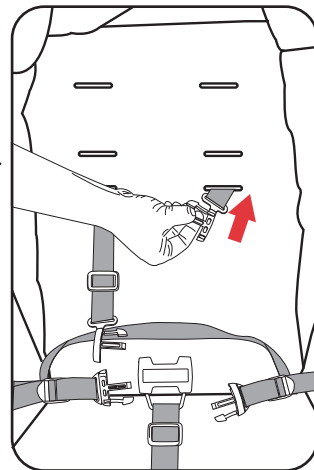

* Depending on the model

⚠ WARNING: USE THE HARNESS AT ALL TIMES.

When not in use disconnect shoulder straps from the waist strap and buckle to prevent strangulation.

A five point harness is provided to restrain your child. Buckle tongues separate for added safety. To reconnect buckle tongues and to secure the child in the harness please follow the steps below carefully.

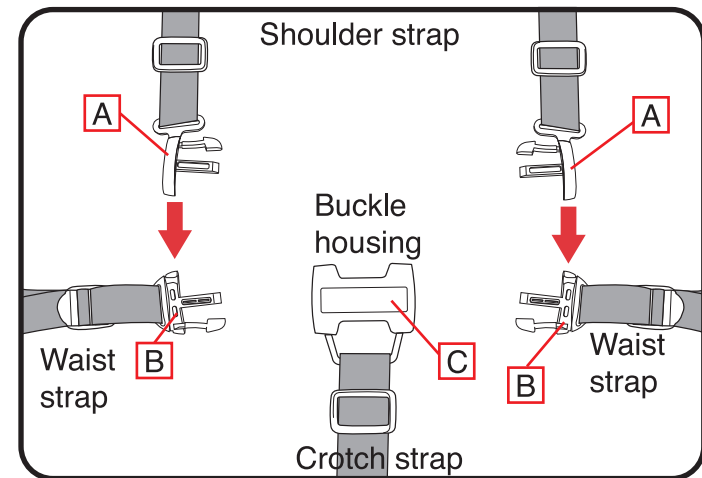

A Position the shoulder strap tongue (A) on the top of the waist buckle tongue (B) on both sides.

08. TO SECURE YOUR CHILD IN THE HARNESS (Cont)

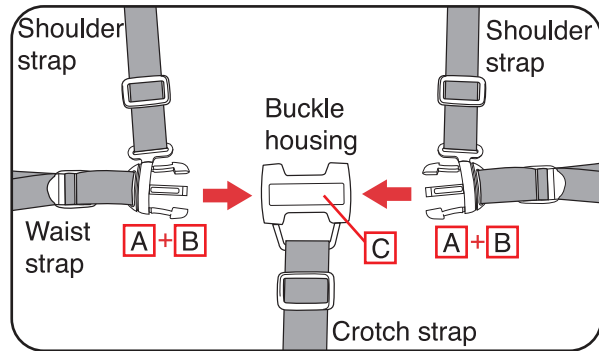

- B Push both buckle tongues (A+B) into the buckle housing (C) until the buckle tongues lock into position.

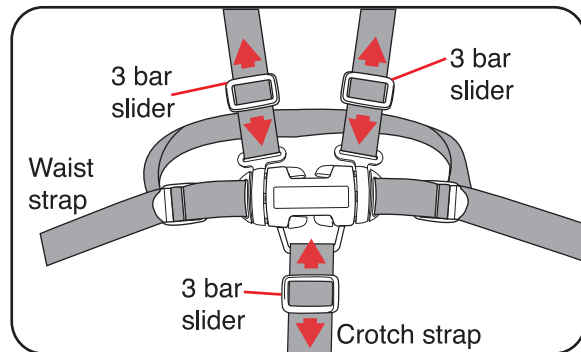

- C Tighten or loosen shoulder and crotch straps by sliding up and down the 3 bar sliders.

08. TO SECURE YOUR CHILD IN THE HARNESS (Cont)

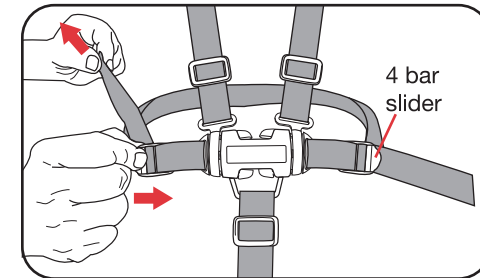

- D Tighten or loosen the waist straps, hold and lift the 4 bar slider and then pull the harness strap, to adjust to the desired fit. The waist strap needs to fit firmly around the child.

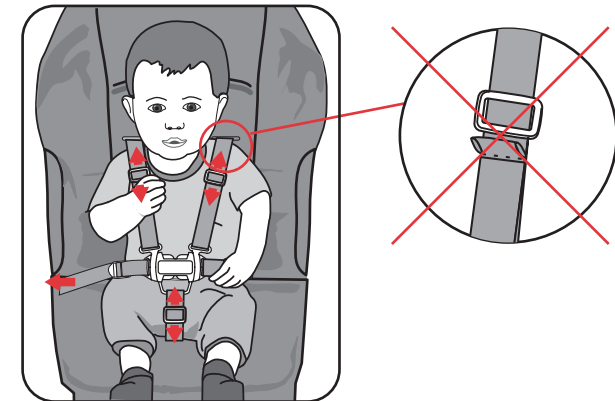

- E Tighten or loosen the shoulder straps, slide the 3 bar slider up or down to adjust to the desired fit. Always adjust the harness strap when changing the seating position of the child.

CAUTION: DO NOT SLIDE 3 BAR SLIDER OVER THE SEWN TAB ON SHOULDER HARNESS.