

Steelcraft[™]

STRIDER SIGNATURE BASSINET

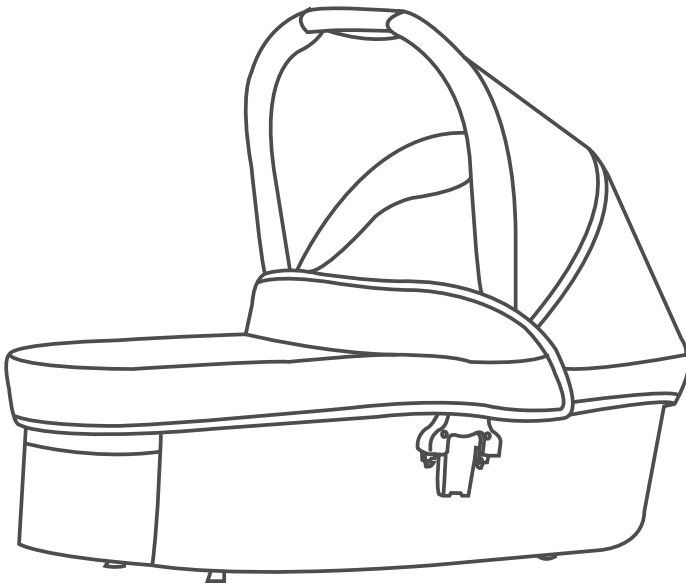

IMPORTANT: KEEP THIS BOOKLET IN A SAFE PLACE FOR FUTURE REFERENCE

Series SA8343

BASSINET WARNINGS

WARNINGS:

- DO NOT USE THE BASSINET ONCE THE CHILD CAN SIT UP.
- IT IS UNSAFE TO USE ACCESSORIES NOT APPROVED FOR USE WITH THIS STROLLER.
- DO NOT USE ANY ACCESSORIES OTHER THAN THOSE APPROVED FOR USE WITH THIS STROLLER BY BRITAX.
- THE MAXIMUM WEIGHT OF THE CHILD USING THIS PRODUCT IS NOT TO EXCEED 9KGS.

IMPORTANT NOTES:

- THE STRIDER SIGNATURE BASSINETS ARE THE ONLY BASSINETS DESIGNED TO FIT THE STRIDER SIGNATURE STROLLERS.
- REMOVE THE STROLLER SEAT OR BABY CAPSULE FROM THE FRAME BEFORE FITTING THE BASSINET.
- ALWAYS REMOVE YOUR CHILD FROM THE BASSINET BEFORE FITTING OR REMOVING THE BASSINET FROM THE STROLLER FRAME.
- THE BASSINET MUST ALWAYS FACE TOWARDS THE HANDLE.
- THE BASSINET MUST BE REMOVED FROM THE FRAME BEFORE FOLDING.
- DO NOT LIFT THE STROLLER BY THE BASSINET.
- THE BASSINET IS SAFE FOR A CHILD TO SLEEP FOR A PROLONGED PERIOD, THE STRIDER SIGNATURE BASSINET MEETS THE REQUIREMENT OF THE AS/NZS 8811.1:2013 - SLEEP SURFACES - TEST FOR FIRMNESS, AND EN 1466:2014/AC:2015 SAFETY REQUIREMENTS FOR CARRY COTS.

MANUAL HANDLING TECHNIQUES

The **SMART** lifting technique

This technique can be used to pick up small light loads from low levels.

Size up the Load

- Assess the load (size, shape and weight).
- Assess whether the load needs to be moved;
- Where is it going to be placed, check that there are no obstructions;
- Assess whether mechanical or human assistance is required.

Move the Load as close to the body as possible

- A load is heavier to lift or carry if it is not close to the body.
- The whole hand should be used to ensure a firm grip.

Always bend your knees

- Maintain balance.
- Keep feet apart and in a comfortable position.
- Minimise lower back bending.
- Bend knees preferable at as large an angle as possible but not at a right angle use a semi squat in preference to a full squat.

Raise the load with your legs

- Achieve the lift smoothly and without jerkiness.
- Maintain the normal curvature of the spine to allow the force of the load to be distributed evenly from the spine to the pelvis.

Turn your feet in the direction that you want to move the load.

- Avoid unnecessary bending, twisting and reaching.
- Change direction by turning your feet and not your back.
- To set the load down, squat down, keep your head up and
- Let your legs do the work.

Remember to 'THINK TALL' chest lifted, shoulders relaxed, chin tucked in and head level.

PARTS LIST

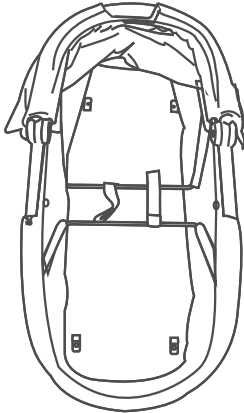

1x Bassinet Frame

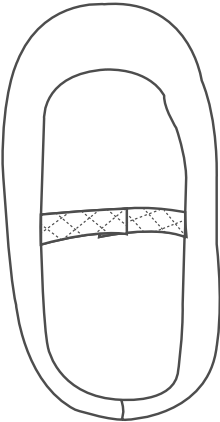

1x Bassinet Liner

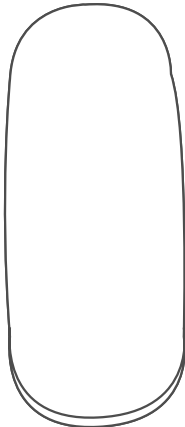

1x Bassinet Mattress

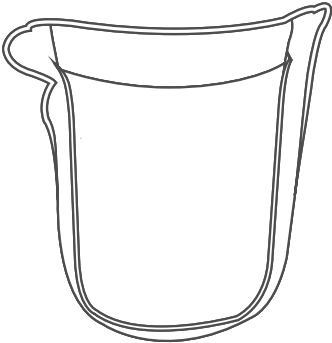

1x Bassinet Boot Cover

BASSINET FEATURES

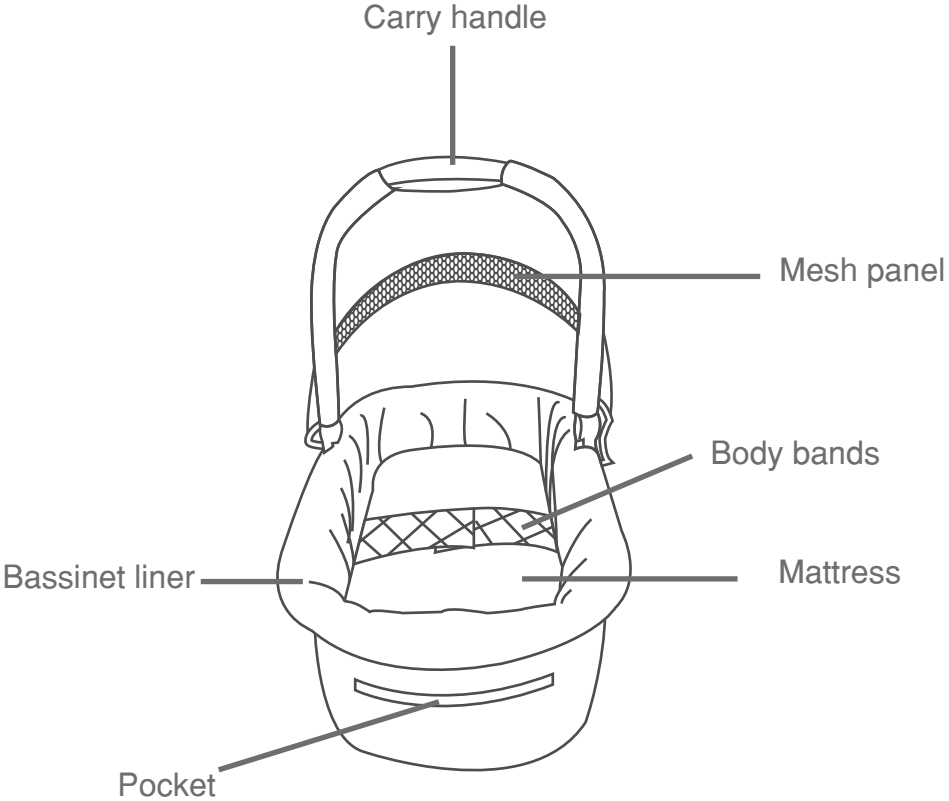

BASSINET FEATURES

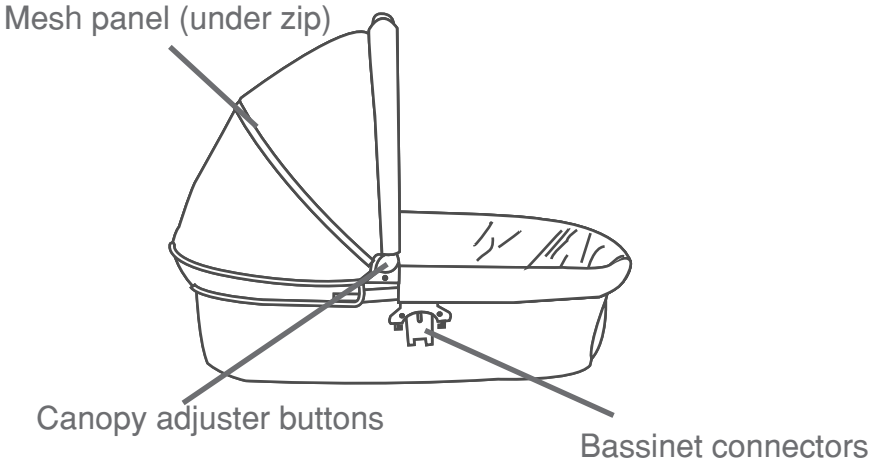
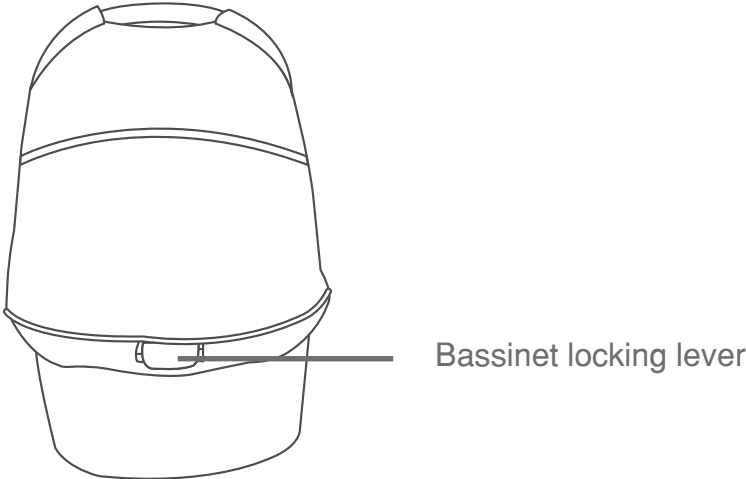

BASSINET ASSEMBLY

OPENING THE BASSINET CANOPY

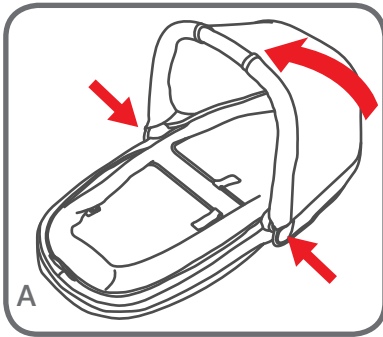

A Rotate the canopy to the upright position by pressing in and holding the canopy adjuster buttons on both sides.

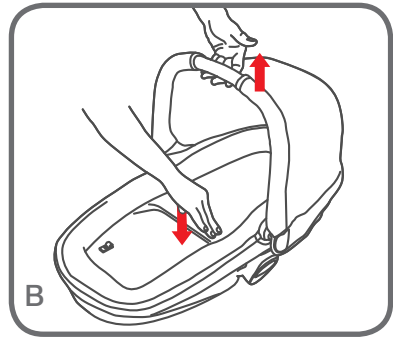

B Press down on the base of the bassinet & pull up on the bassinet canopy handle to raise the sides of the bassinet.

OPENING THE BASSINET FRAME

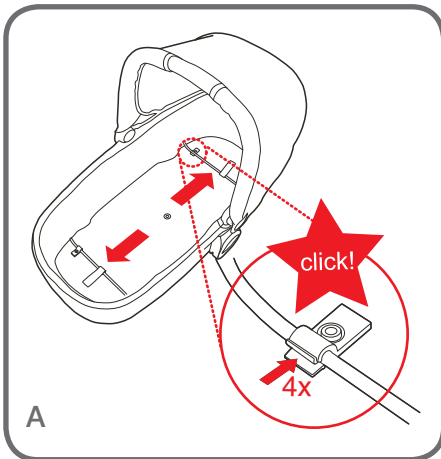

A Pull the bassinet frame support rods outward by the straps until each rod slides and locks under all 4 clips. Push down lightly on the top edges of the bassinet to ensure that the frame support rods are firmly locked in place.

BASSINET ASSEMBLY

ATTACHING THE BASSINET LINER

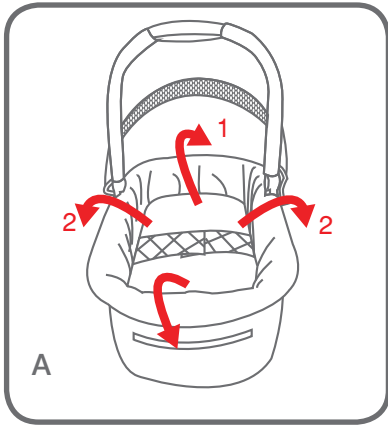

A Place the liner in the bassinet and pull it over each corner of the bassinet ensuring the opening in the liner is aligned with the locking lever. Ensure the body band is facing upwards. Fasten the hook and loop tabs under the bassinet locking lever (1) and around each of the handle mouldings on sides (2).

INSERTING THE MATTRESS

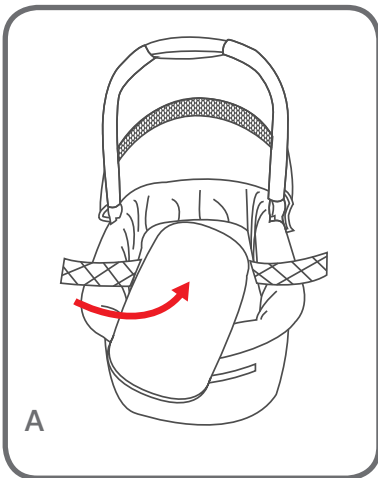

A Place the mattress into the bassinet. Place the body band on the top surface of the mattress.

BASSINET OPERATION

USING THE CANOPY

⚠ CAUTION: ENSURE THE CANOPY IS SECURELY ENGAGED BEFORE YOU LIFT THE BASSINET BY THE HANDLE.

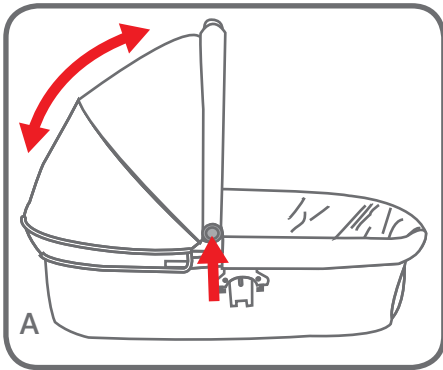

A Fasten the hook tabs located on both sides of the canopy and on the back of the canopy to the loop tabs on the bassinet. Press and hold the canopy adjuster buttons on both sides and then rotate the canopy to the desired position.

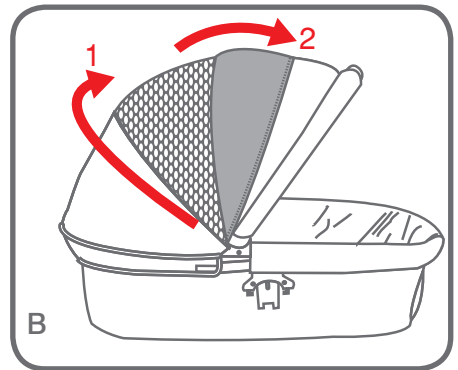

B To extend the canopy fully unzip the centre section and to expose the mesh section of the canopy, fold the fabric panel over to the front section of the canopy.

BASSINET OPERATION

ATTACHING THE BOOT COVER

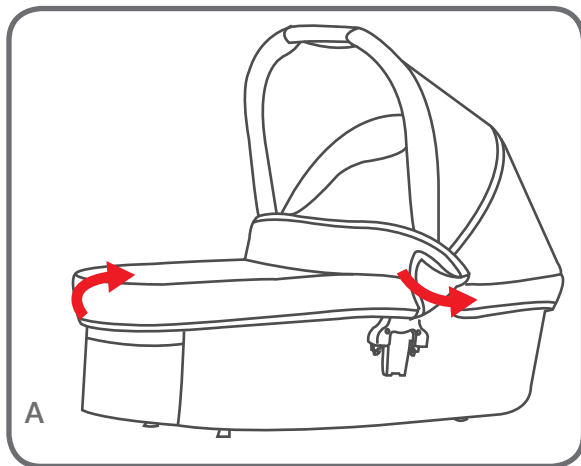

A Place the bassinet boot cover over the bassinet and attach the hook strips on each side of the boot cover to the loop tab on each side of the canopy.

ATTACHING THE BASSINET TO THE STROLLER FRAME

PLEASE REFER TO PAGE 3 FOR SMART LIFTING TECHNIQUES.

IMPORTANT NOTE:

ALWAYS REMOVE YOUR BABY FROM THE BASSINET BEFORE INSTALLING OR REMOVING THE BASSINET.

PLEASE NOTE: The bassinet can only be installed rearward position (baby facing parent position) on the stroller frame. The frame will not fold with the bassinet installed so it must be removed before folding.

BASSINET OPERATION

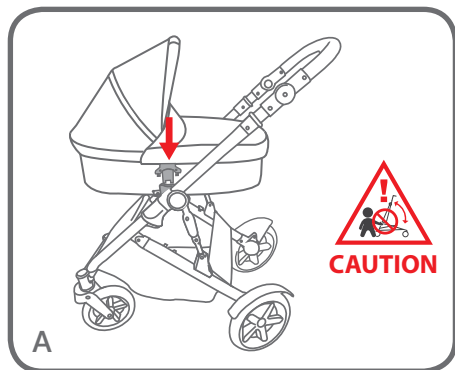

A The bassinet must face the stroller handle.
Align the bassinet directly over the frame sockets.

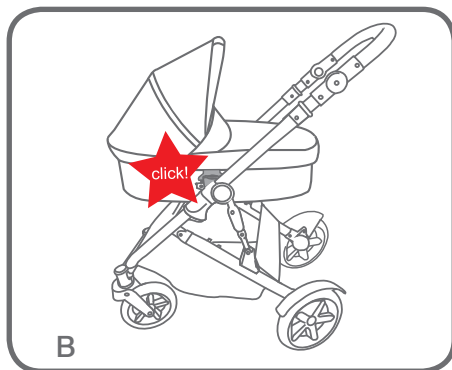

B Push the bassinet down until it is locked into the stroller frame sockets.
Please ensure it is locked.

REMOVING THE BASSINET FROM THE STROLLER FRAME

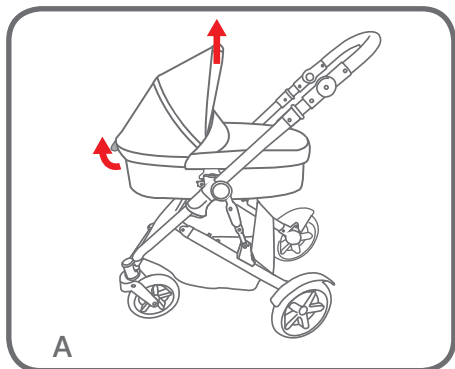

A Firmly lift and hold the bassinet locking lever up to release the bassinet from the stroller frame socket and same time lift the bassinet up with handle.

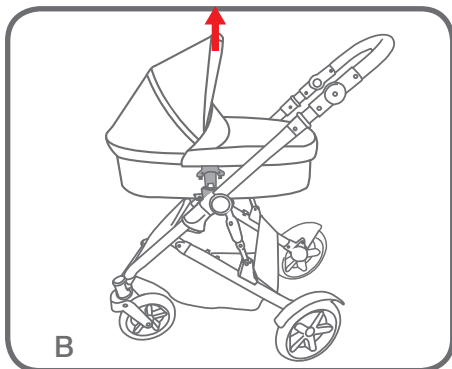

B Lift the bassinet completely out of the stroller frame.

BASSINET OPERATION

USING THE BODY BAND

PLEASE NOTE: A BODY BAND IS INSTALLED IN THE BASSINET FOR OPTIONAL USE.

Place the baby band around the baby's abdomen close to the body without constricting the baby and carefully fasten the two sides of the body band with the hook and loop strips.

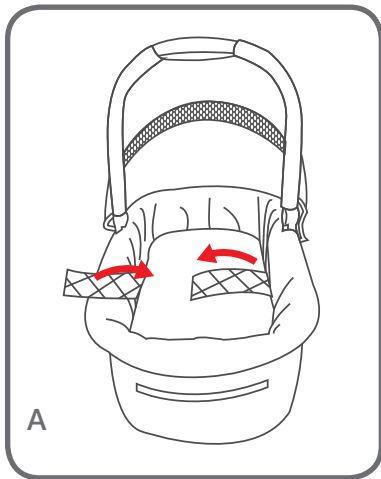

A Place the mattress into the bassinet.
Place the body band on the top surface of the mattress.

CARE & MAINTENANCE

- To prolong the life of your bassinet keep it clean and do not leave it in the direct sunlight for extended periods of time.
- Removable fabric covers and trims may be cleaned using warm water with household soap or mild detergent. Allow it to dry fully, preferably away from the direct sunlight.
- Non removable fabric covers and trims may be spot cleaned using a damp sponge with soap or a mild detergent. Allow it to dry completely before folding or storing it away.
- In some climates the covers and trims may be affected by mould and mildew, to help prevent this occurring, do not fold or store the product if it is damp or wet. Always store the product in a well ventilated area.
- Always check parts regularly for tightness of screws, nuts and other fasteners - tighten if required. To maintain the safety of your nursery product, seek prompt repairs for bent, torn, worn or broken parts. Use only those parts and accessories approved by Steelcraft.

THIS PRODUCT IS NOT INTENDED FOR COMMERCIAL USE.

Steelcraft™

BRITAX CHILDCARE PTY. LTD.

A.B.N. 55 006 773 600

Level 4, 650 Lorimer Street, Port Melbourne, Victoria 3207, Australia

Phone: (03) 9288 7288 Fax: (03) 9311 5798

CUSTOMER SERVICE

1300 303 330 - Australia 0508 688 822 - New Zealand

Due to our continuing program of development, Britax reserves the right to alter the specifications, color or design without any further notice.

The Steelcraft trademark is the property of Britax Childcare Pty.Ltd - Australia.

The Britax trademark is the property of Britax Childcare Holdings Limited - UK.

Visit the Britax website at: www.britax.com.au or email us at au-custserv@britax.com

Due to the variations in the style and design of our products the illustrations used in this instruction booklet are generic.

This product is designed to comply with Australian and New Zealand standard AS/NZS 2088:2013 "Prams and Strollers - Safety Requirements", AS/NZS 8811.1:2013 - Sleep surfaces - test for firmness, and EN 1466:2014/AC:2015 Safety requirements for carry cots.

©2018 Copyright Britax Childcare Pty. Ltd. Australia