

Safe-n-Sound™

Convertible Child Restraint with AHR™ Headrest.

SERIES NO. 7200/A/2004

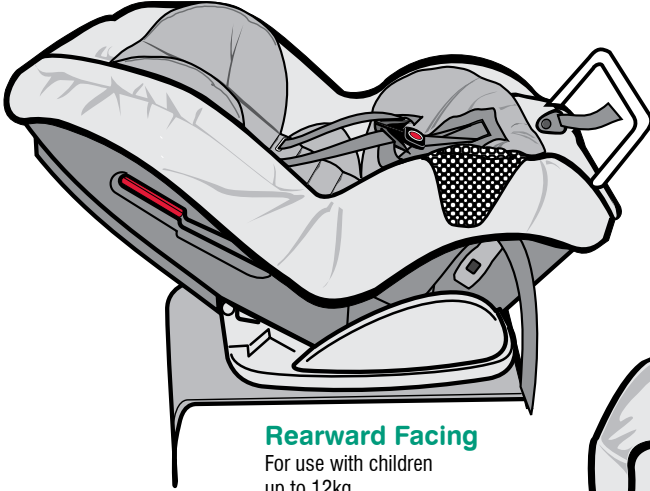

Rearward Facing

For use with children
up to 12kg.

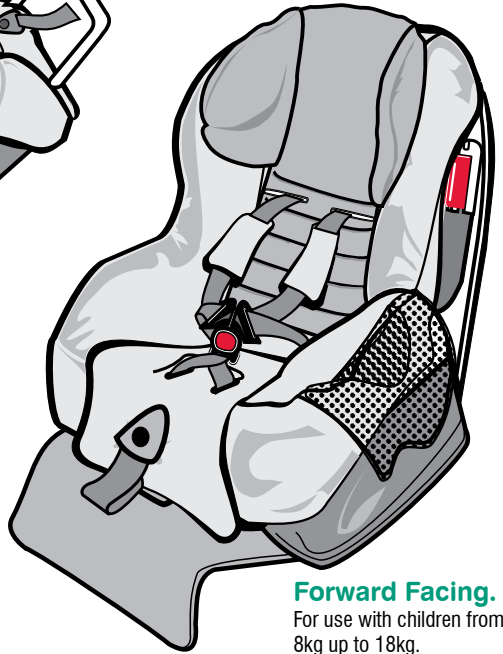

Forward Facing.

For use with children from
8kg up to 18kg.

Instructions for Installation & Use

INFORMATION FOR BUYERS;

FOR USE WITH CHILDREN FROM BIRTH TO 18KG.

CHECK THAT THIS CHILD RESTRAINT WILL FIT IN YOUR CAR.

IMPORTANT: KEEP THIS BOOKLET IN THE PLACE PROVIDED ON THE CHILD RESTRAINT.

FOR BABY AND CHILD USE

| | |
|-----------------------|---|
| WHO TO CONTACT..... | 2 |
| INTRODUCTION..... | 3 |
| WARNINGS..... | 3 |
| PRE-INSTALLATION..... | 4 |

| | |
|---------------------------|----|
| CARE AND MAINTENANCE..... | 22 |
| ACCESSORIES..... | 24 |
| IN CASE OF ACCIDENT..... | 26 |
| NOTES..... | 27 |

FOR BABY USE

| | |
|------------------------------------|----|
| SPECIAL FEATURES FOR BABY USE..... | 6 |
| SUITABLE FOR USE..... | 7 |
| WARNINGS..... | 7 |
| HOW TO SETUP & USE HEADREST..... | 8 |
| HOW TO INSTALL..... | 10 |
| HOW TO USE..... | 13 |

FOR CHILD USE

| | |
|-------------------------------------|----|
| SPECIAL FEATURES FOR CHILD USE..... | 15 |
| SUITABLE FOR USE..... | 16 |
| WARNINGS..... | 16 |
| HOW TO SET UP & USE HEADREST..... | 17 |
| HOW TO INSTALL..... | 18 |
| HOW TO USE..... | 21 |

WHO TO CONTACT

Britax Childcare Pty. Ltd.

(Incorporated in Victoria)

A.B.N 55 006 773 600

Head office and registered address:

99 Derby Road Sunshine Victoria 3020

PO Box 147 Sunshine Victoria 3020

Customer Service: 1300 303 330

New Zealand Office

Britax Childcare NZ Limited.

PO Box 100-247 Auckland 9

Customer Service: 0800 688 822

The Safe-n-Sound, AHR and Cushion Technology trademarks are the property of Britax Childcare Pty. Limited. (Australia).

The Britax trade mark is the property of Britax Excelsior Limited (UK).

Visit the Britax Web Site at www.britax.com.au or email custserv@britax.com.au

We reserve the right to alter this product without notice.

©1997-2009 Britax Childcare Pty. Ltd.

This product is covered by Australian and overseas patent applications. Patents Pending.

INTRODUCTION

CAREFULLY READ ALL THE INSTRUCTIONS FOR INSTALLATION. IN THE EVENT OF DOUBT ABOUT THE METHOD OF INSTALLATION, CONSULT BRITAX CHILDCARE OR AGENT OR A CHILD RESTRAINT FITTING STATION AUTHORIZED BY A RELEVANT TRANSPORT AUTHORITY OR, IN NEW ZEALAND, THE AGENT FOR THE VEHICLE.

No child restraint can guarantee absolute protection from injury in every crash. However, to ensure that your child gets all the protection designed into the restraint PLEASE READ AND FOLLOW THESE INSTRUCTIONS EXACTLY and use only Safe-n-Sound (Britax) recommended parts and accessories.

If you have purchased a model with the added protection of Side Impact Cushion Technology™ you can see the Side Impact Cushion fitted on pages 6 and 15. There is no installation or assembly required to activate the Side Impact Cushion, it only functions in a side crash to protect the occupant.

WARNINGS

- Use the restraint exactly as shown in the instructions.
- Fit the restraint firmly to the car seat.
- Fit the harness firmly to the child.
- A loose restraint or harness is dangerous.
- Supervision of children is needed because they may be able to undo buckles and adjusters.
- **DO NOT LEAVE CHILDREN UNATTENDED IN THE CAR.**
- Do not use seat belt extenders, even if the car seat belt is not long enough to secure the child restraint.
- Do not alter or modify this restraint.
- Repairs must only be done by the manufacturer or agent.
- Do not allow the restraint to come into contact with polishes, oils, bleach and other chemicals.
- Destroy the restraint if it has been in a severe crash, even if no damage is visible.
- **DO NOT USE THIS RESTRAINT WITHOUT A COVER.**
- Regularly check the restraint components, straps & other fitments for correct function and condition. Seek prompt repair.
- To ensure baby's back is evenly supported do not put more than one nappy on the baby and make sure the nappy is not thickly folded at the back.
- **DO NOT USE CHILD RESTRAINTS IN A SEATING POSITION WHERE AN AIRBAG IS FITTED. FOLLOW THE CAR MANUFACTURER'S RECOMMENDATIONS.**
- The restraint should not be purchased or sold as a second hand item. It is recommended not to use child restraints older than 10 years as the protection in an accident may be reduced.
- The restraint is not intended to be a substitute baby cot or bed. It is only designed to enable safe transportation of children in motor vehicles.
- Straps may be damaged by unsecured cargo in a collision. Secure or remove hazardous cargo before using this strap.
- **THIS RESTRAINT IS NOT SUITABLE FOR USE IN A HATCHBACK OR WAGON WHERE THE ANCHORAGE STRAP MAY FALL INTO A SPLIT IN THE SEAT BACK.**
- Protect all webbing from abrasion and cutting by sharp corners and edges.
- **THIS RESTRAINT MUST BE ATTACHED TO A CHILD RESTRAINT ANCHORAGE POINT IN THE CAR. REFER TO A CAR OWNER'S HANDBOOK FOR LOCATION OF ANCHORAGE POINTS. REFER TO A CHILD RESTRAINT FITTING STATION IF NO ANCHORAGE POINTS ARE IN THE MOTOR CAR.**

PRE-INSTALLATION

Consult the vehicle owner's handbook for location of anchorage fittings or anchorage points and the possible use of spacers. Some vehicles may have an anchor fitting fitted by the vehicle manufacturer. If anchorage points cannot be found refer to car manufacturer or local child restraint fitting station or traffic authority for optimum position of anchorage point and the use of spacers.

IMPORTANT WARNING: THE ATTACHMENT CLIP COVER MUST ALWAYS BE USED AS IT PREVENTS THE RISK OF INCORRECT FITMENT OF THE ATTACHMENT CLIP TO THE ANCHOR FITTING. ALWAYS ENSURE THAT THE ATTACHMENT CLIP IS CORRECTLY ENGAGED TO THE ANCHOR FITTING AND NOT HOOKED OR FITTED TO ANY OTHER OBJECT BEFORE EACH USE OF THE RESTRAINT. THIS IS ESPECIALLY IMPORTANT IN VEHICLES SUCH AS STATION WAGONS, VANS, HATCH BACKS OR VEHICLES WITHOUT A FIXED PARCEL SHELF, SINCE THE ANCHOR POINT IS USUALLY NOT VISIBLE.

IMPORTANT INSTALLATION NOTE:

In some vehicles the anchor fitting in the rear vertical panel can only be installed in one way. Please refer to vehicle owner's handbook or a child restraint fitting station for correct method.

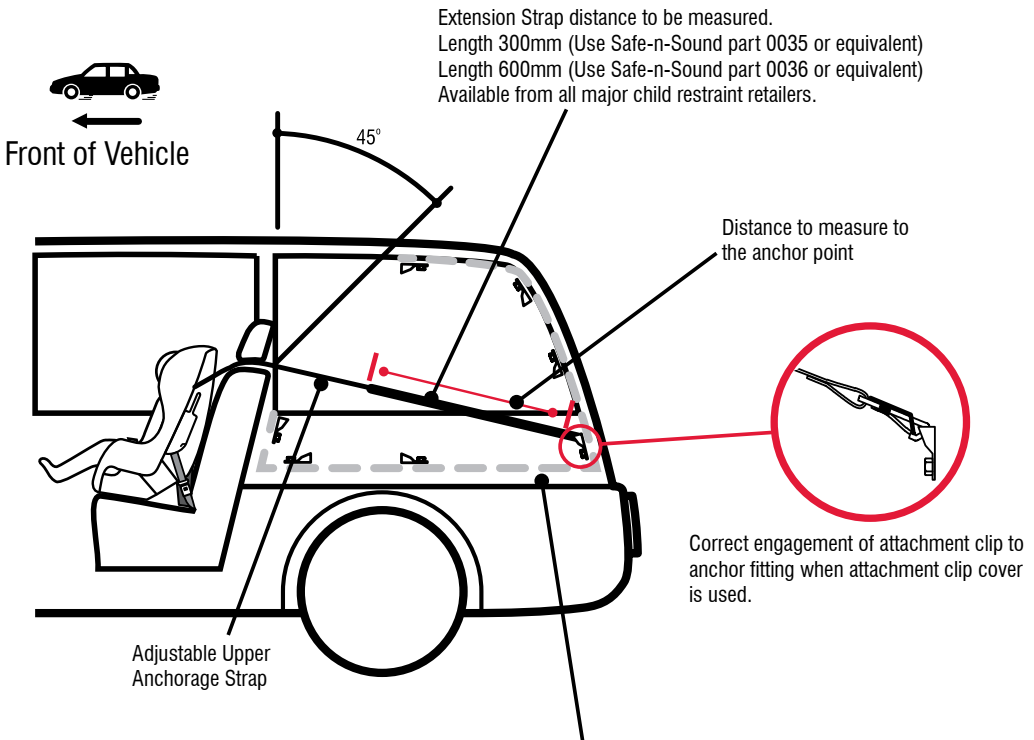

The shaded areas of this diagram illustrate the possible locations of the anchor fitting. Within each shaded area is an anchor fitting showing the correct way to install the fitting. Ensure the anchor fitting is aligned as illustrated unless stated otherwise in the vehicle Owners handbook.

PRE-INSTALLATION ANCHOR FITTING:

If the car is fitted with child restraint anchorage point...

Locate the anchorage point behind the rear seating position to be used. Consult the car owners handbook for the location of the anchorage points. The anchorage point should be directly behind and central to the restraint. Remove thread plug from the parcel shelf, floor/roof, etc. and install anchor bolt and fitting as shown right.

CAUTION: DO NOT OVERTIGHTEN ANCHOR BOLT. OVERTIGHTENING MAY FRACTURE OR BREAK BOLT. MAXIMUM TORQUE IS 20 N.M. (14.75 ft.lb.)

Note: Minimum of five full turns of anchor bolt is required before tightening force is applied.

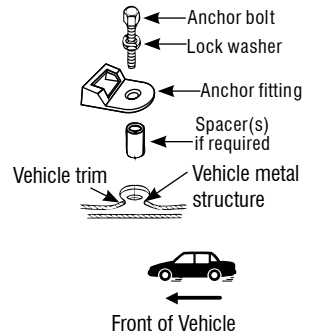

If the car is not fitted with child restraint anchorage points...

For Sedans only - Drill 9mm diameter hole in the parcel shelf on the centre line of the seating position as shown right. Before drilling the hole, check the underside for accessibility.

For vehicles other than Sedans - In Australia, consult your nearest child restraint fitting station or traffic authority for vehicle inspection to find the best, correct position for the placement of the anchorage point, and for the correct attachment bolt length and use of spacers. In New Zealand, consult the agent for the vehicle.

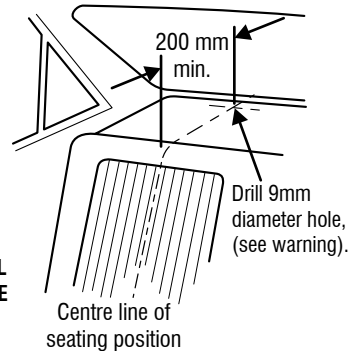

WARNING: CHILD RESTRAINTS MUST NOT BE ATTACHED TO UNSOUND METAL OR TO WOOD, OR SYNTHETIC STRUCTURES. WHEN DRILLING THE 9 MM HOLE DO NOT DRILL THROUGH FUEL LINES, FUEL TANKS, ELECTRICAL WIRING, OR RADIO SPEAKERS. WEBBING STRAPS MUST BE PROTECTED FROM SHARP CORNERS AND EDGES.

THE ANCHOR FITTING MUST BE USED ONLY AS DESCRIBED ABOVE. IT MUST NOT BE HOOKED ONTO ANY OTHER OBJECT.

Note to Queensland purchasers: The installation of anchorage points must be approved by authorised officers appointed by Queensland Transport. Authorised officers can be sourced from all Queensland Transport Customer Service and Queensland Ambulance Service Centres.

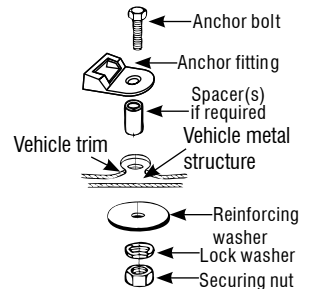

ONLY USE A 5/16 UNC GRADE 5 BOLT. IF THE BOLT IS NOT THE CORRECT LENGTH THE CAR MANUFACTURER'S HAND BOOK CAN PROVIDE ADVICE ON THE CORRECT LENGTH BOLT.



Note: Marking on the top of a Grade 5 Bolt.

SPECIAL FEATURES

To be used only in a rearward-facing position for a child weighing up to 12kg.

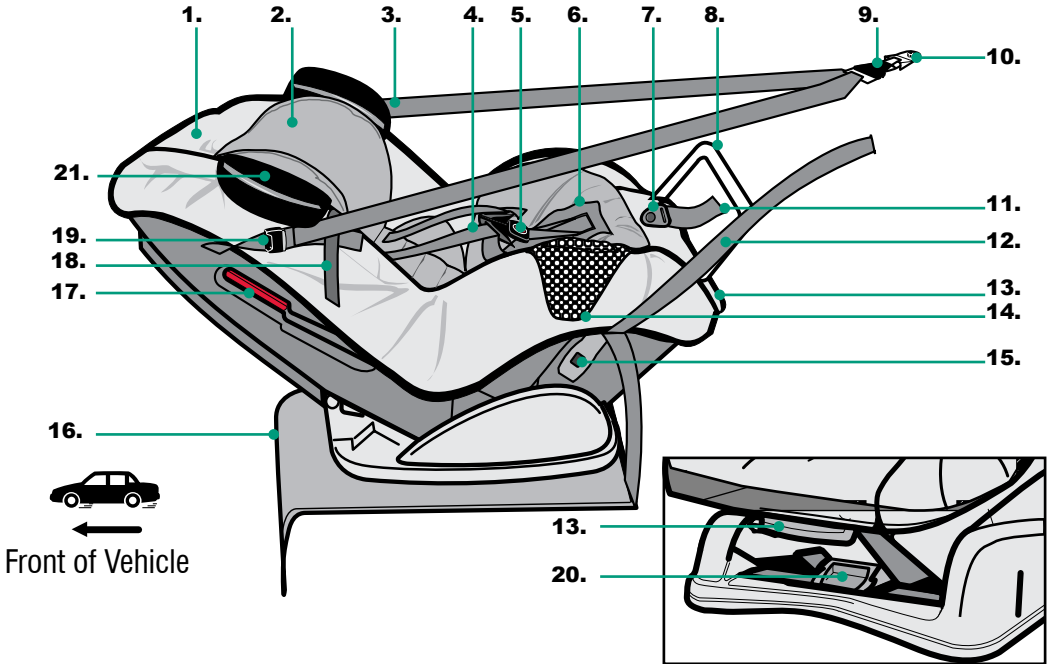

1. Padded cover for baby's comfort (may vary in style)
2. Adjustable Headrest (with speakers, if fitted)
3. Adjustable Upper Anchorage Strap
4. Fully adjustable 6 point harness.
5. Quick Release Buckle (Red button)
6. Baby Insert
7. Harness Adjuster Button
8. Stabilising Bar for Baby use
9. Attachment Clip and Cover
10. Anchor Fitting

11. Harness Adjustment Strap
12. Vehicle seat belt.
13. Blue Recline Latch
14. Pocket (if fitted)
15. Rear facing Lock off (if fitted)
16. Messy Mat (if supplied)
17. Forward facing sash belt lock off (if fitted)
18. Upper Anchorage Storage Strap
19. Upper Anchorage Strap Adjuster
20. Yellow Release Latch
21. Side Impact Cushion Technology™ Protection (if fitted)

SUITABLE FOR USE

TO BE USED WITH A LAP SASH OR LAP ONLY SEAT BELT IN THE FRONT OR BACK OF MOST CARS WITH FORWARD-FACING SEATS.

To be used only in a rearward-facing position for a child weighing up to 12 kg.

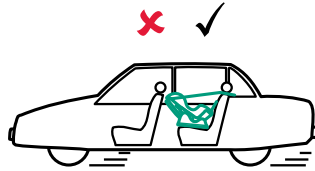
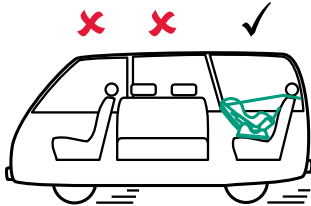

The purchaser should check the measurements between the front of the seat back of the rear seat and all front seats in the car in which the child restraint is intended to be used, to ensure that the space is sufficient.

In certain vehicles, where the rear seat is too small, the only position possible for the restraint is the front seat adjusted as rearward as possible.

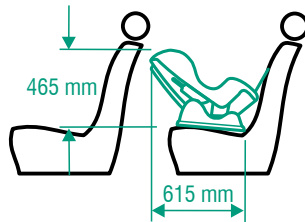
**! WARNINGS**

DO NOT USE RESTRAINT IN REARWARD FACING MODE WITHOUT STABILISING BAR FULLY EXTENDED.

Do not use the restraint without the Upper Anchorage Strap correctly attached.

DO NOT USE A REAR FACING CHILD RESTRAINT WHERE AN AIRBAG IS FITTED IN FRONT OF THE SEATING POSITION.

Do not use the baby insert after baby reaches 10kg and over.

When using the restraint in the front seat, do not use the rear seat. The upper anchorage strap will need to pass the rear seating position to attach to an anchorage point.

Do not use on any vehicle seat which faces sideways or rearwards.

Never leave babies or toddlers in a stationary car in the sun because of the risk of heat exhaustion.

Ensure babies and toddlers have adequate ventilation and are shaded from direct sunlight through side or rear windows.



Do not allow the front seat to alter the installed position of the restraint

HOW TO SETUP

ADJUSTING HARNESS STRAP HEIGHT & HEADREST: FOR BABY USE REARWARD-FACING

Correct fitment of the harness is very important as it restrains the baby in the restraint. The headrest must be in the correct position & the harness must fit firmly around upper torso of the baby and be positioned so as to leave the baby's arms and legs free.

For baby up to 12 kg the headrest must be in the position where the top of the shoulder strap slots are nearest to the child's shoulders, but not lower than the child's shoulders. If your baby weighs more than 12 kg then the restraint should be converted for "child use". (Refer to Forward Facing section page 15.)

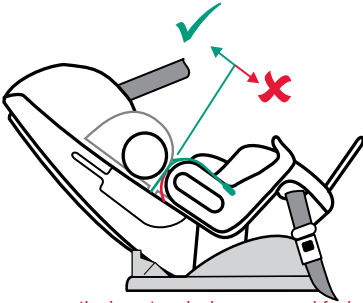

NOTE: Always use the insert pad when rearward facing or in baby mode for small and premature babies. Discontinue the use of the insert pad if there is insufficient room for the baby.

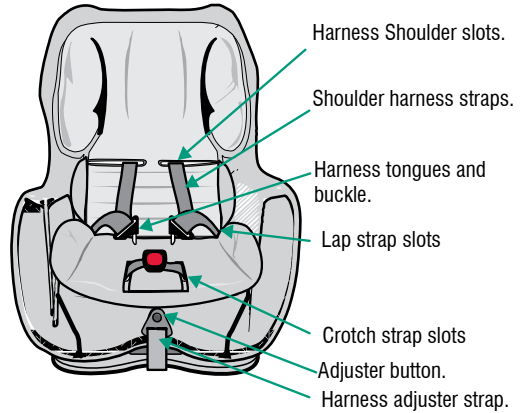

ADJUSTING HEADREST HARNESS STRAP HEIGHT

- Loosen the harness straps before adjusting the headrest.
- You do not need to remove the restraint from the vehicle to adjust the harness or headrest positions. Small adjustments maybe possible with the baby still in the seat, the baby will need to be supported to allow the headrest to be rotated forward for adjustment.
- To adjust the headrest, gently pull the top of the headrest forward as shown, (see photo), and pull up or push down so that the shoulder strap slot is level with or slightly above your child's shoulder. (If fitted, do not adjust the headrest by pulling on the Side Impact Cushion).
- Release headrest so that it moves back and locks into position, Ensure that it has locked in position by gently pushing down on it.
- Ensure there are no twists in the harness strap and the buckle tongues face the correct way.
- If the headrest is moved up, then down with the child in the seat, before use, check that the headrest cover has not bunched up behind child's back.

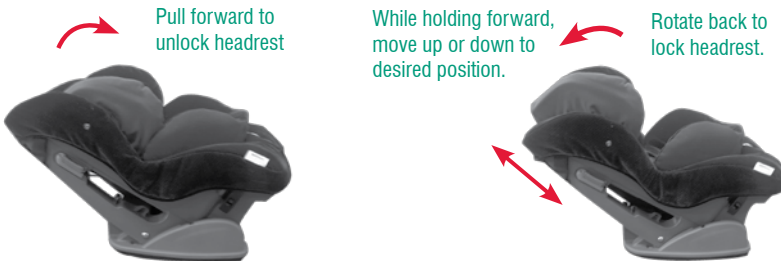

HOW TO SETUP

INSTALLING INTO VEHICLE (REARWARD FACING)

- A. The restraint is normally packaged in the fully upright child use mode so if you need to use it for baby use you must first fully recline the restraint, to convert the restraint to baby use mode as shown below.
- B. If Upper Anchorage Strap is folded up for storage under Storage Strap then lengthen. Fully press Adjuster Button (A) while pulling Upper Anchorage Strap (B) to lengthen.

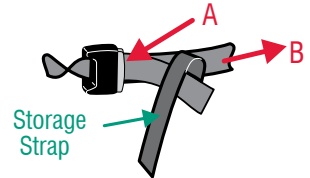

FULLY RECLINE IN CHILD USE MODE:

Place one hand on the front corner of the base firmly while with the other hand push the blue recline latch up to unlock, continue pulling restraint forward until fully reclined. The yellow latch prevents over reclining when installed forward facing. The seat belt may need to be slackened and retightened.

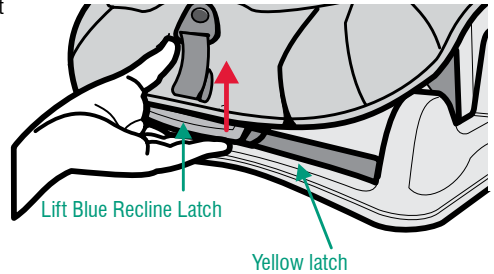

CONVERT TO BABY USE MODE:

Once fully reclined, press the yellow latch located under the restraint body while with the other hand push the blue recline latch up to unlock, continue pulling restraint forward until fully reclined into baby use mode.

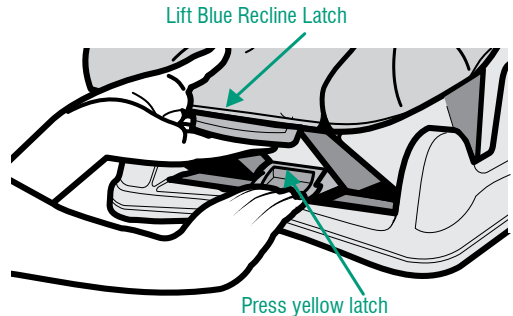

HOW TO INSTALL

A. Unhook hook & loop attachments & gently lift the cover, fully extend out stabilising bar and gently push bar forward until a click is heard. Stabilising Bar is now latched in place.

Note: Do not re-attach cover hook & loop until you have installed seat belt.

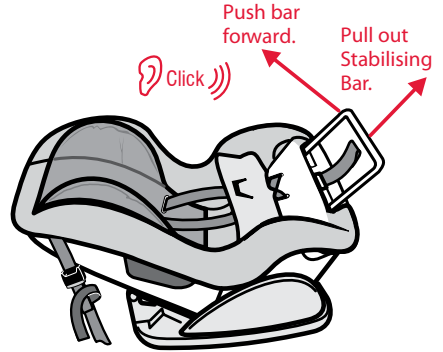

B. Position restraint rearward facing in the chosen seating position.

C. Fully lengthen seat belt and feed the seat belt between the restraint cover and the restraint body through seat belt slots in restraint. Place the seat belt under any comfort foam.

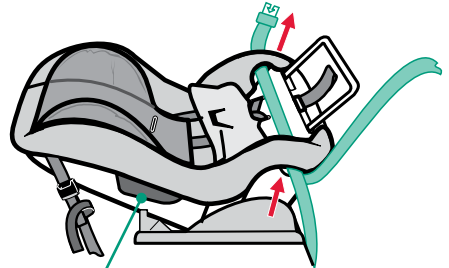

D. Engage seat belt buckle & tongue.

Note: Seat belt buckle and tongue must not rest between restraint cover and restraint. If seat belt buckle is adjustable, adjust buckle as low as possible away from the restraint.

E. Re-attach hook and loop attachments.

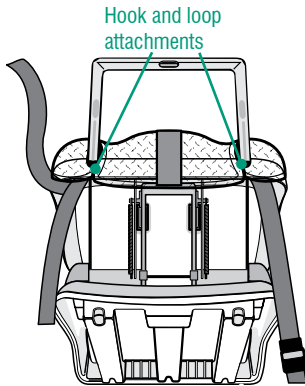

On the opposite side to the seat belt buckle, only pass the lap portion of the belt through the lock-off and lock in place.

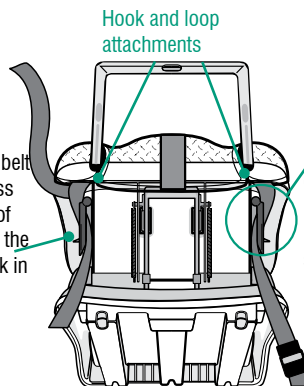

On the car seat belt buckle side, pass both lap and sash seat belt through the lock-off and lock in place

Rear facing seat belt lock-off (if fitted)

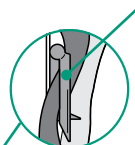

HOW TO INSTALL

- F. Align restraint centrally to the chosen seating position as shown below. Pull sash portion of seat belt until all slack is removed from Lap portion of seat belt. Adjust seat belt to hold the restraint firmly against the vehicle seat back. For retractor seat belts, allow excess belt to feed back into retractor. Lock the rear facing seat belt lock-off (where fitted) to prevent the seat belt slacking.

Fully press Adjuster Button (A) while pulling Upper Anchorage Strap (B) to lengthen.

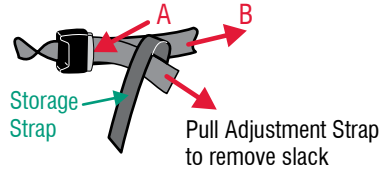

- G. Fit the attachment clip to the anchor fitting as shown above right. Make sure to remove as many twists as possible from the upper anchorage strap.
- H. Tighten adjustable upper anchorage strap by pulling adjustment strap to remove slack, but do not over-tighten causing the restraint base to lift off the vehicle seat. This will usually be done once the baby has been harnessed into the seat.

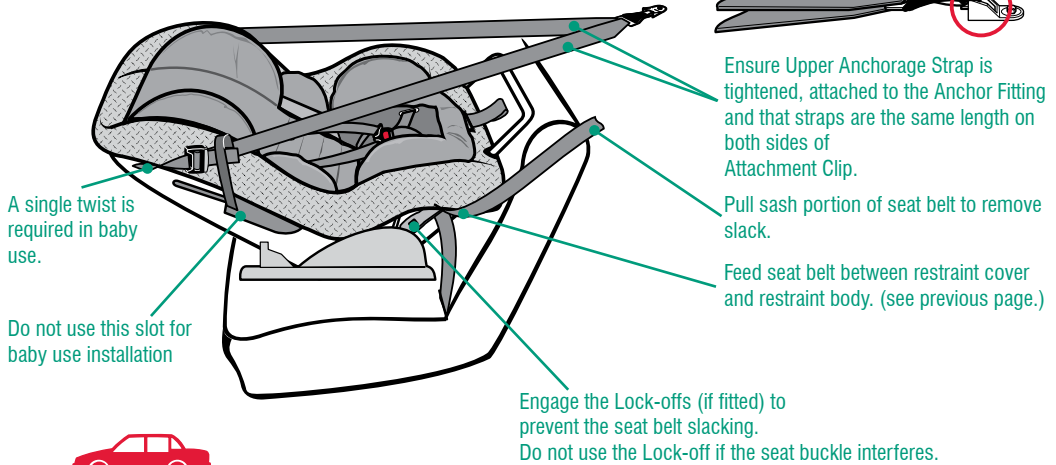
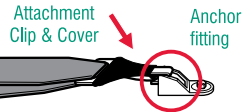

Front of vehicle



WARNING:

DO NOT USE RESTRAINT IN REARWARD FACING MODE WITHOUT STABILISING BAR FULLY EXTENDED.

THE UPPER ANCHORAGE STRAP MUST ALWAYS BE FITTED WHEN THE CHILD RESTRAINT IS USED IN A VEHICLE.

HOW TO INSTALL

Important: If using an Extension Strap, positioning the Attachment Clip above the baby may lead to injury in an accident therefore make sure that the Attachment Clip is not positioned in front of the vehicle seat.

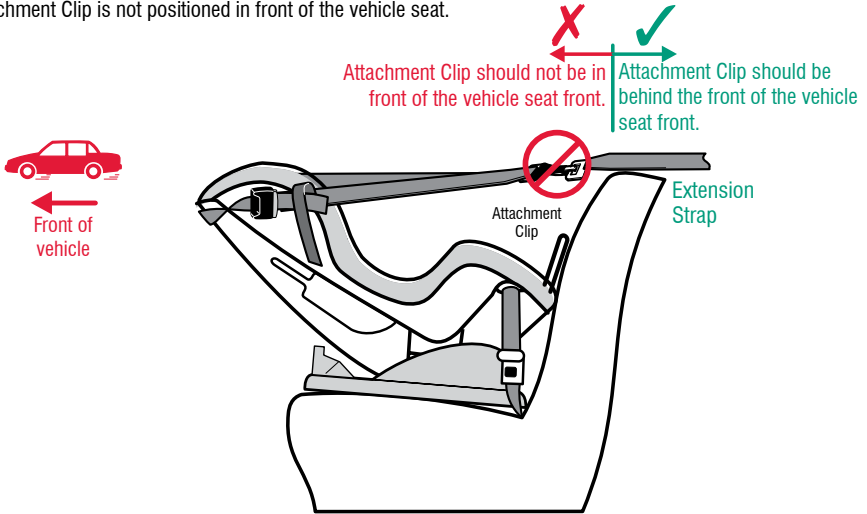

ANGULAR ADJUSTMENT OF RESTRAINT

Some vehicle seats have more rearward slope than others. If the angle of the seat causes the baby to be too upright for comfort, the angle may be altered by placing a firm packing between the seat and the underside of the base. Packing can be a firmly rolled up towel or nappy.

Do not remove all of the rearward slope by over packing. Always leave a rearward slope angle of approximately 10 to 15 degrees as shown

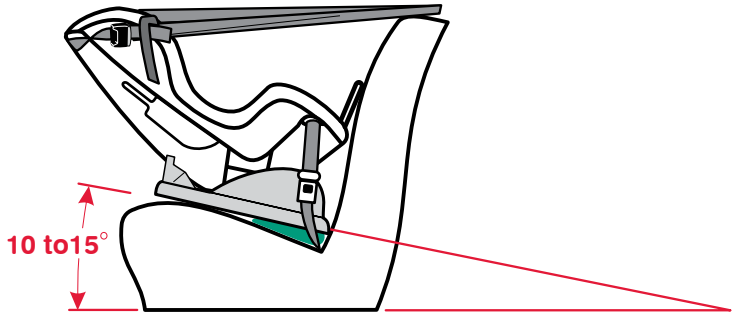

TO REMOVE RESTRAINT FROM VEHICLE

- Disengage seat belt tongue from buckle and remove from restraint.
- Fully press Upper Anchorage Strap Adjuster Button (A) while pulling Upper Anchorage Strap (B) to slacken as shown right. In some vehicles loosening of the Upper Anchorage Strap may be difficult. If so, try pushing the restraint against the vehicle seat back or slightly lifting the restraint to release the tension.
- Disengage Attachment Clip from Anchor Fitting. The child restraint is now disconnected.

Fully press Adjuster Button (A) while pulling Upper Anchorage Strap (B) to lengthen.

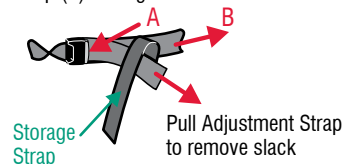

HOW TO USE

PLACING BABY INTO RESTRAINT

- A. Ensure the headrest and shoulder straps are adjusted to the correct height for your child (see page 8).
- B. Slacken the Upper Anchorage Strap and allow the straps to fall to the sides of the restraint for easy access to the baby.
- C. Slacken Harness Straps by pushing and holding the Harness Adjustment Button, grasping BOTH shoulder harness straps and pulling out the desired amount of slack. Release harness adjustment button when there is enough slack and place harness to each side of the restraint.
- D. Lay baby on their back into restraint and fit harness as shown above. Make sure the baby is dressed to allow harness buckle to be pulled up between baby's legs e.g. a jump suit. Make sure the baby's arms and legs are free. Never wrap baby in a blanket before placing in restraint.

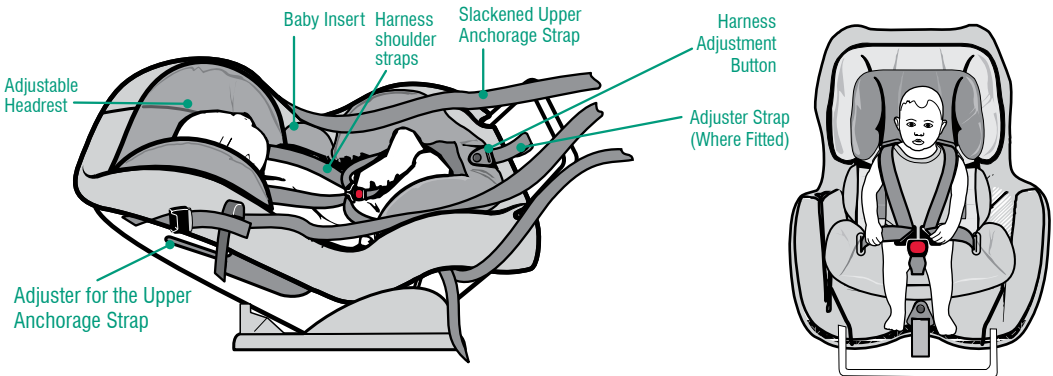

- E. Fit either harness tongue into the harness buckle followed by the other tongue until a click is heard. Should the second tongue not insert, press the red button and reinsert the tongues. Ensure secure engagement by pulling harness straps.

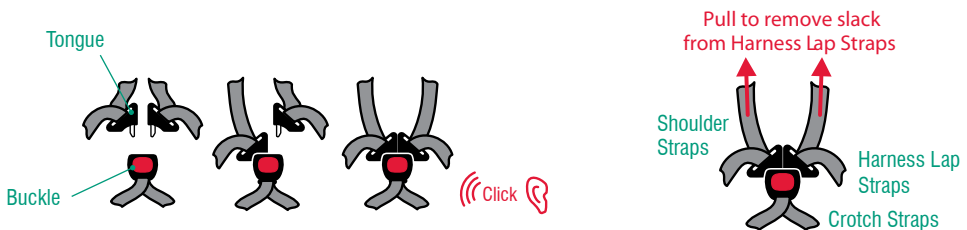

- F. Remove slack from harness lap straps by pulling shoulder straps.

HOW TO USE

Make sure that nothing is obstructing harness straps and that baby's arms and legs are free.
Do not use restraint if straps do not tighten and contact Safe-n-Sound or Britax Childcare Customer Service.

- H. Tighten Adjustable Upper Anchorage Strap by pulling Adjustment Strap to remove slack as shown.

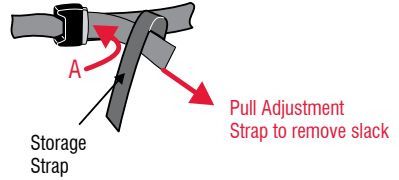

IMPORTANT: The Baby Insert Pad is designed to snugly support baby for extra support and comfort and must be used for smaller babies, less than 10kg. Discontinue use if Baby Insert Pad creates discomfort for larger babies or once baby reaches 10kg.

REMOVING BABY FROM RESTRAINT

- Press Upper Anchorage Strap Adjuster Button while pulling Upper Anchorage Straps to slacken. Allow Upper Anchorage Straps to fall to the sides for easy access into restraint.
- Push and hold the Harness Adjustment Button while pulling both Shoulder Harness Straps to slacken harness to the desired amount.
- Press red button on Harness Buckle then both Harness Tongues will be released. Move each shoulder strap to baby's side then pick up baby.

SPECIAL FEATURES FOR CHILD USE

To be used only in a forward-facing position for a child weighing from 8 kg to 18 kg.

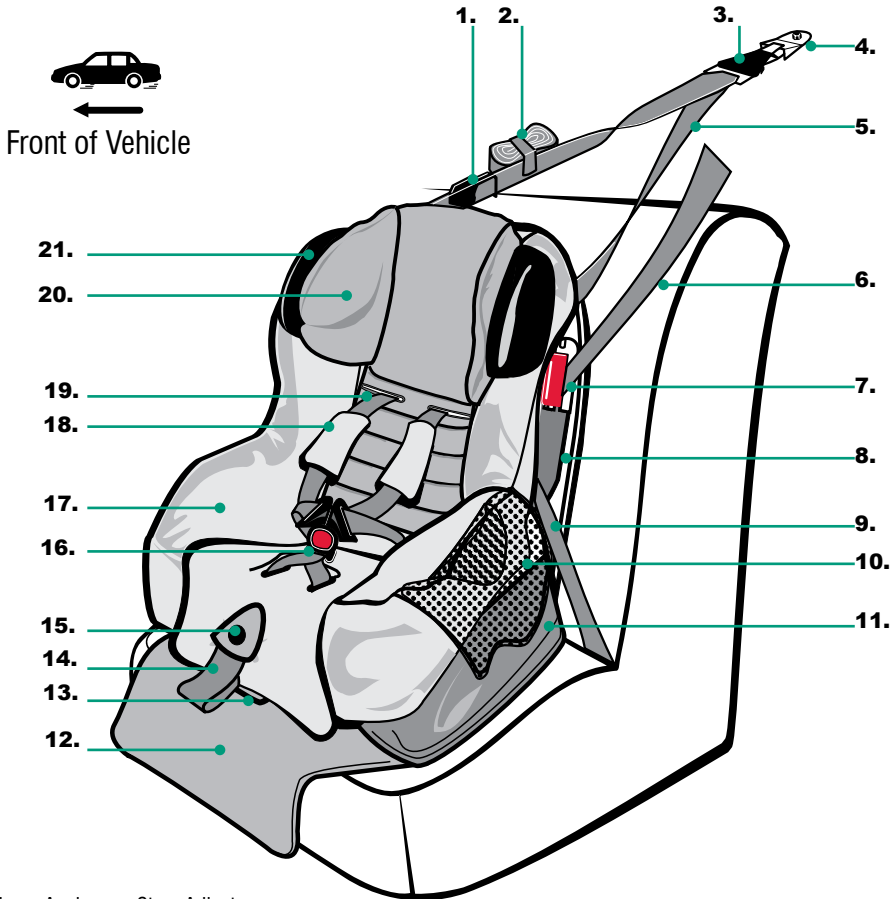

- | | |
|--|--|
| 1. Upper Anchorage Strap Adjuster | 12. Messy Mat (if fitted) |
| 2. Upper Anchorage Storage Strap | 13. Blue Recline Latch |
| 3. Attachment Clip and Cover | 14. Harness Adjustment Strap |
| 4. Anchor Fitting | 15. Harness Adjuster Button |
| 5. Adjuster Upper Anchorage Strap | 16. Quick Release Harness Buckle (Red button) |
| 6. Sash belt portion of a lap sash seat belt | 17. Padded Cover for comfort |
| 7. Forward facing sash belt lock-off (if fitted) | 18. Shoulder pads (if fitted) |
| 8. Seat belt path (forward facing) | 19. Fully Adjustable 6 point harness |
| 9. Lap belt portion of a lap sash seat belt | 20. Adjustable Headrest (with speakers, if fitted) |
| 10. Pocket (if fitted) | 21. Side Impact Cushion Technology™ Protection (if fitted) |
| 11. Base (shown in child use mode) | |

SUITABLE FOR USE

TO BE USED WITH A LAP-SASH OR LAP ONLY SEAT BELT IN THE FRONT OR BACK OF MOST CARS WITH FORWARD-FACING SEATS.

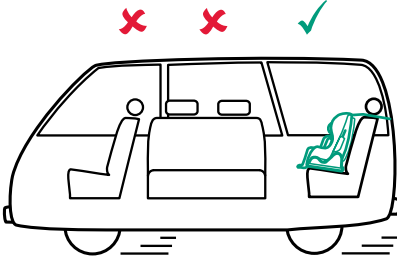

To be used only in a forward facing position for a child weighing from 8 kg to 18 kg.

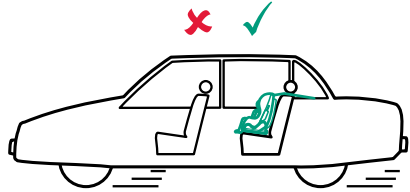

WARNING

DO NOT USE RESTRAINT IN FORWARD- FACING MODE WITH THE REAR FACING MODE STABILISING BAR PULLED OUT.

Do not use the restraint without the Upper Anchorage Strap correctly attached.

If your vehicle is not fitted with an anchor point, please contact a Safety Restraint Fitting Station authorised by the relevant State Government Body for correct fitment of the restraint. In New Zealand contact the agent for the vehicle. The upper anchorage strap must be attached to an anchorage point using an extension strap if necessary.

When using the restraint in the front seat, do not use the rear seat. The upper anchorage strap will need to pass the rear seating position to attach to an anchorage point.

Do not use on any vehicle seat which faces sideways or rearwards.

Do not use the Baby Insert in Forward Facing 'Child Use'.

DO NOT USE A CHILD RESTRAINT IN A SEATING POSITION WHERE AN AIRBAG IS FITTED. FOLLOW CAR MANUFACTURER'S RECOMMENDATIONS.

HOW TO SETUP

ADJUSTING HARNESS STRAP HEIGHT & HEADREST: FOR CHILD USE FORWARD-FACING

Correct fitment of the harness is very important as it restrains the child in the restraint. The harness must fit firmly around the upper torso of the child and be positioned so as to leave the child's arms and legs free.

The headrest must be in the position where the top of the shoulder slots are nearest to the child's shoulders, but not more than 25mm below the child's shoulders. If the headrest is in the top position and the harness straps are still more than 25 mm below the level of the child's shoulders then the child is too tall for the restraint and the restraint should not be used.

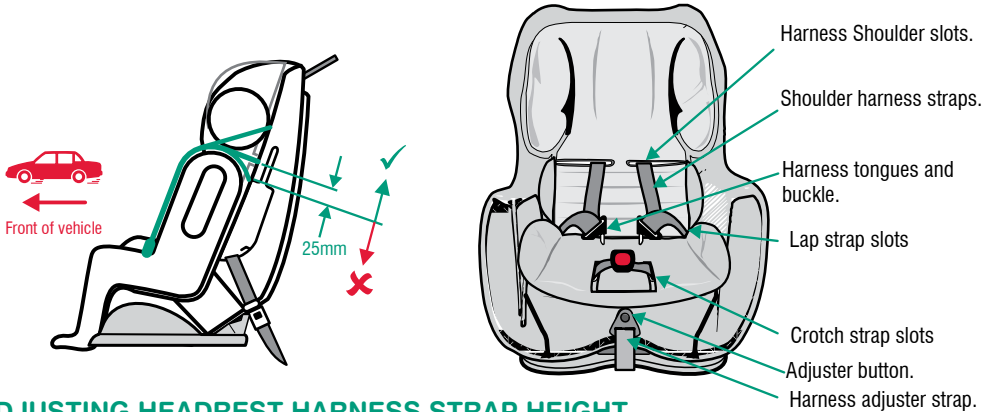

ADJUSTING HEADREST HARNESS STRAP HEIGHT

- Loosen the harness straps before adjusting the headrest.
- You do not need to remove the restraint from the vehicle to adjust the harness or headrest positions. Small adjustments maybe done with the child the seat, the child will need to lean forward to allow the headrest to be pulled forward.
- To adjust the headrest, gently pull the top of the headrest forward as shown, (see photo), and pull up or push down so that the shoulder strap slot are level with or slightly above your child's shoulder.

NOTE: For comfort ensure the bottom edges of the headrest are not contacting the child's shoulders. (If fitted, do not adjust the headrest by pulling on the Side Impact Cushion).

- Release headrest so that it moves back and locks into position, Ensure that it has locked in position by gently pushing down on it.
- Ensure there are no twists in the harness strap and the buckle tongues face the correct way.
- If the headrest is moved up, then down with the child in the seat, before use, check that the headrest cover has not bunched up behind child's back.



HOW TO INSTALL

INSTALLING INTO VEHICLE (FORWARD FACING) (UPRIGHT OR RECLINED)

 **WARNING: DO NOT USE RESTRAINT IN FORWARD-FACING POSITION WITH THE STABILISING BAR PULLED OUT.**
Do not recline into baby position when using restraint in forward facing child use mode.
IMPORTANT: Ensure harness and headrest are in the correct position. (Refer to page 17)

A. If the Stabilising Bar is extended, unhook hook & loop attachments and push trim away from restraint.

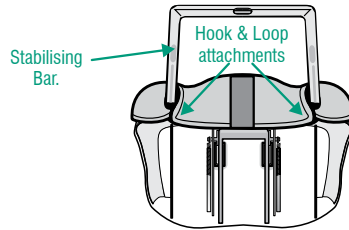

B. Press blue button on left side (facing seat) and gently push stabilising bar down and then into the recessed area.

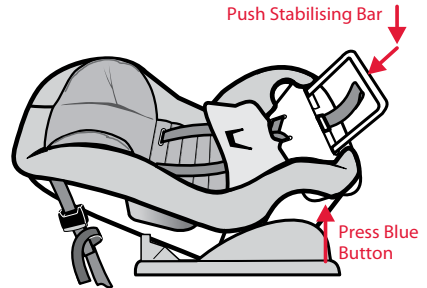

C. Re-attach hook & loop attachments on trim.

D. Convert the restraint to child use mode by placing one hand over rear corner of the base and lift the top end of restraint with the other hand until audible click is heard.

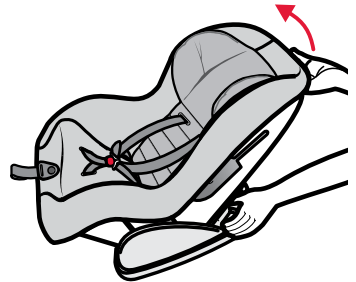

HOW TO INSTALL

INSTALLING INTO VEHICLE (FORWARD FACING) (UPRIGHT OR RECLINED)

- E. Determine whether an upright or reclined position is preferred and adjust if necessary (see below).
- F. Place one hand on the front corner of base firmly, while with the other hand push the blue recline latch up to unlock and push back until the restraint is at the desired position. Ensure the blue recline latch is engaged into position by pushing on the restraint.



FULLY UPRIGHT
CHILD USE MODE



FULLY RECLINED
CHILD USE MODE

Push blue recline latch up while moving restraint into desired recline position.

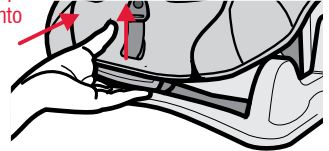

- G. Position restraint in forward facing mode and align restraint centrally to the chosen seating position as shown on page 20. Some vehicle seat fabrics (particularly velours) may be damaged by a child restraint used continuously. We recommend the need of a messy mat or thick towel to keep the vehicle seat in good condition.

- H. Fully lengthen seat belt. Insert seat belt into child use seat belt path as shown right, ensuring that the seat belt is behind the harness straps and that the lap part of the seat belt is below the hooks as shown right.

- I. Engage seat belt buckle and tongue, ensure to remove all slack from lap part of seat belt by pulling sash belt. Adjust the seat belt to hold the restraint firmly against the vehicle seat. For inertia/retractable seat belts, allow excess belt to feed back into retractor.

Push down on seat

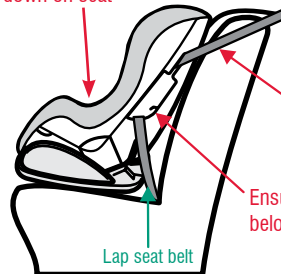

Pull sash portion of seat belt to remove slack

Ensure lap part of seat belt is below the hooks

Lap seat belt

HOW TO INSTALL

INSTALLING INTO VEHICLE (FORWARD FACING) (UPRIGHT OR RECLINED)

J. Fit the attachment clip to the anchor fitting as shown. Make sure to remove as many twists as possible from the upper anchorage strap.

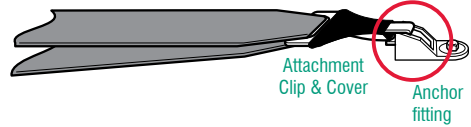



K. Tighten Adjustable Upper Anchorage Strap by pulling adjustment strap to remove slack as shown below, but do not over-tighten causing the restraint base to lift off the vehicle seat. Fold up excess strap and use storage strap to neatly store excess strap away from child's reach.

SEAT BELT 'LOCK OFF' (WHERE FITTED)

If seat belt 'lock-off' is fitted, follow steps above, through to point K. Press the seat belt 'lock off' while threading the sash part of the seat belt through the slot in the 'lock off', then release the 'lock off' (refer to illustration below).

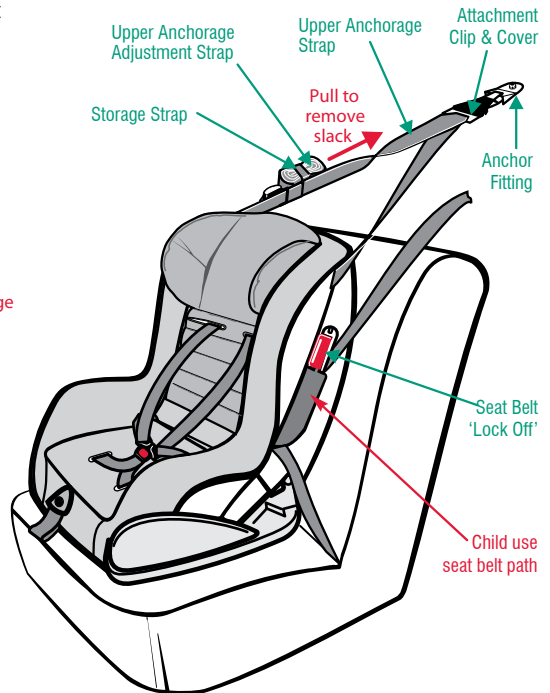
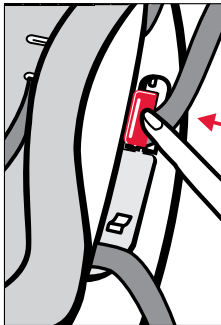
Push restraint firmly downward, while pulling sash part of seat belt to tighten through 'lock off'. This will prevent the seat belt loosening.



 **IMPORTANT:** Always roll up the excess Upper anchorage Strap.

HOW TO USE

PLACING CHILD IN THE RESTRAINT

A. Lengthen harness by pushing and holding the Harness Adjustment button while pulling on either shoulder strap until the harness will accommodate the child.

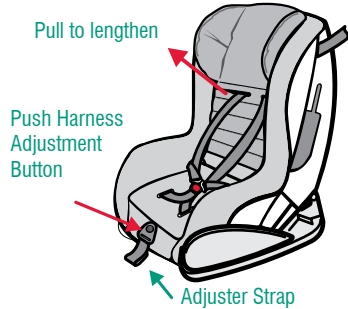

B. Place child in the restraint and feed each arm through shoulder straps. Pull harness buckle up between child's legs.

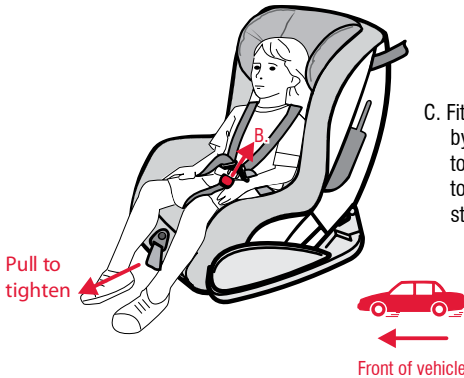

C. Fit either harness tongue into the harness buckle followed by the other tongue until a click is heard. Should the second tongue not insert press the red button and reinsert the tongues. Ensure secure engagement by pulling harness straps.

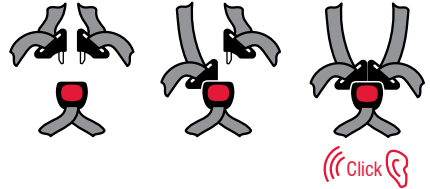

D. Ensure all slack is removed from harness lap straps by pulling shoulder straps the pull harness adjustment strap to adjust harness to a comfortable but firm fit. Check that the slack in straps is removed. Shoulder Harness Straps must fit firmly to the child. A loose harness could result in serious injury in an accident.

Do not use restraint if straps do not tighten and contact your local authorised service agent for repair.

TO REMOVE CHILD

Press red button on harness buckle then both harness tongues will be released. Lift the shoulder straps from the child's shoulders.

TO RECLINE RESTRAINT

The child restraint may be reclined or positioned upright without removing the child from the restraint. You will be able to gain partial recline from upright position by just pushing the blue recline latch up and pulling the seat forward (see page 19). The extent of the recline will be limited by the location of the anchorage point. Loosening of the upper anchorage strap may be required when positioning the restraint to either an upright or reclined position. Once the required position has been determined ensure to tighten the upper anchorage strap and recheck the car seat belt tension i.e., all slack to be removed.

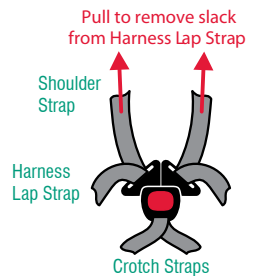

CARE & MAINTENANCE

The restraint has a flame retardant cover which is removable for cleaning. Cleaning instructions are on the care label attached to the cover. If fluffy cover is fitted then washing cover prior to use will remove excess fluff. Ensure that the inside of the buckle is free of foreign matter. Cleaning instructions for the buckle are on page 27. Use only mild soap and water to clean all metal and plastic parts of the restraint. Do not use chemicals or cleaning agent. Do not pull sticky items from covers as the cover may be damaged - soak in water and gently remove.

COVER (STYLE MAY VARY)

The cover has been designed to protect your child when seated in the restraint. Care should be taken if children either eat or drink while in the restraint as some food or drink products may cause damage or marking to the cover.

TO REMOVE COVER:

- A. Remove the restraint from vehicle.
- B. Disengage harness tongues from harness buckle.
- D. Remove any accessories.
- E. Remove headrest cover and seat cover as follows.
- F. Unhook the cover at the top and bottom of the restraint. Peel cover from outer rim of the body starting **A** from on both sides and at **B**, at the top. Refer to drawing below and at Push button **C**
- G. Remove the cover while feeding Crotch Buckle, Harness Tongues and strap through the lap and crotch strap slots in the cover.

Note: If the restraint is fitted with Side Impact Cushion, the headrest trim has elastic which pulls over the Side Impact Cushion that can be easily removed and replaced.

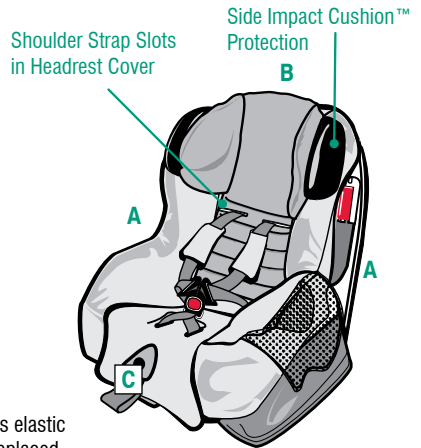

TO REPLACE COVER:

- A. Feed the Harness Tongues & shoulder straps through Lap strap slots and matching shoulder strap slots in the cover.
- B. Stretch cover over the top of the restraint first at **B**, then the sides at **A** and then stretch the cover around the rim of the restraint.
- C. Re-fit the Seat Cover attachments.
- D. Feed Crotch Buckle through slots in cover
- E. Ensure trim is stretched over Push Button housing **C** and ensure none of the harness straps are twisted.
- F. Fit headrest cover over headrest and feed harness thru slots in cover.
- G. Refit baby insert if required.

REGULAR CARE OF THIS RESTRAINT:

Please check the following items regularly to ensure the safety of your child:

- A. Check the webbing for fraying.
- B. Check that the buckle clicks and is not sluggish or sticky in operation.
- C. Ensure there are no cracks in moulding or the plastic moulding.
- D. Check the harness adjuster is operating and is clamping the webbing.
- E. If any part of the restraint is cracked or broken, seek repair immediately or replace the child restraint.

TO CLEAN HARNESS BUCKLE:

If sticky liquids such as baby formula, fruit juice, etc. get inside your Harness Buckle, it may become sluggish. An indication of a sluggish Harness Buckle is that you cannot hear a click when engaging the Harness Tongues. To restore the Harness Buckle to good working order it needs to be cleaned as follows:

- A. From the underside of the restraint pull each crotch 3-bar slide then turn 3-bar slide and push through each slot to remove the Harness Buckle from the restraint.
- B. Place the Harness Buckle under warm (max. 40 degrees Celsius) running water as shown below. Let the water run through the mouth of the buckle for five minutes.

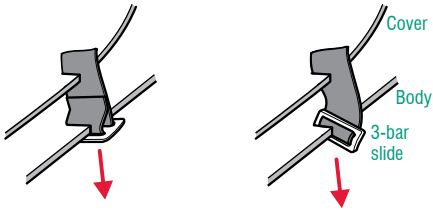

- C. Engage and disengage the Harness Tongues and Buckles several times until a strong audible click is heard.

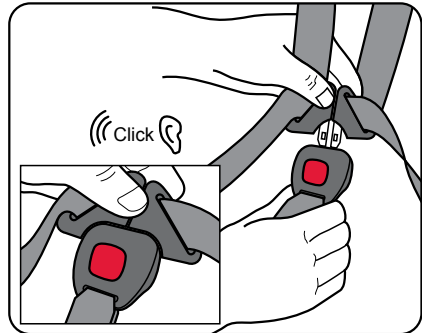

- D. If you still cannot hear a strong audible click after engaging the Harness Tongues & Buckle, then repeat cleaning several times. If the Harness Buckle cannot be returned to its original working condition then contact Safe-n-Sound or Britax Childcare Customer Service.

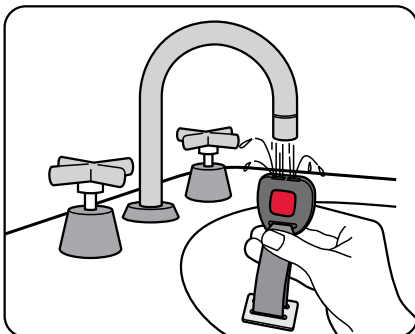

- E. Refit the harness buckle to the restraint with the red button facing out & feeding each 3-bar slide through appropriate slot.

ACCESSORIES



WARNING

ONLY USE SAFE-N-SOUND SEAT COVERS AND ACCESSORIES THAT ARE DESIGNED AND TESTED FOR USE WITH THIS PRODUCT.

The following instructions apply to accessories that may be supplied with this restraint at point of purchase. If not, a variety of accessories are available from various retailers of Safe-n-Sound products.

HOOD (IF FITTED)

The hood has been designed to protect your child from direct sunlight.

- A. Attach the elastic straps at the back of the hood to the hooks at the rear of the restraint.
- B. Attach together the hook & loop sewn on the ends of the hood & on the sides of the trim.

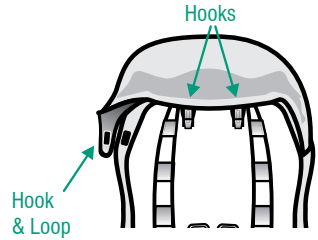

POCKETS (IF FITTED)

The pockets sewn on the trim are designed for your convenience. They can hold those necessary items that you need at a moments notice. e.g. Bottle, face washer, toy etc. They can also hold a CD or MP3 player.

Caution: If using the pocket to store filled bottles, please ensure contents are not contaminated due to prolonged storage. Ensure contents are not crushed by car door when closing.

CROTCH PAD (IF FITTED)

The Crotch Pad is designed to provide extra comfort for baby or child and is fitted to the restraint as follows: Feed Crotch Buckle through the slot in crotch pad as shown.

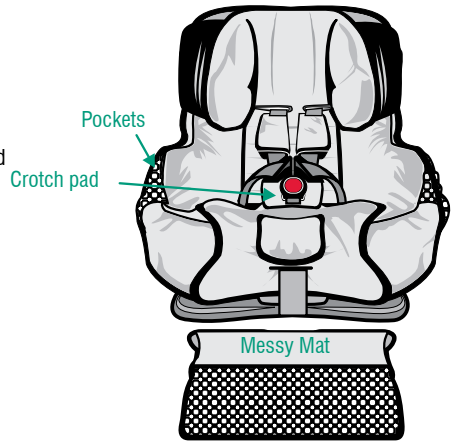

COVER (STYLE MAY VARY)

The cover has been designed to protect your child when seated in the restraint. Care should be taken if children either eat or drink while in the restraint as some food or drink products may cause damage or marking to the cover.

IMPORTANT: Do not pull sticky items from covers as the cover may be damaged - soak in water and gently remove.

MESSY MAT (IF SUPPLIED)

The messy mat has been specifically designed to protect your vehicle seat from children's shoes rubbing against it. If the Messy Mat has been supplied it must be used to protect the car upholstery.

Place pocket on edge of seat, smooth back toward seat join ('A') and fit in any excess messy mat into the join of the car seat ('A').

CAUTION: The messy mat pocket is only for small, light items. DO NOT overload the pocket with heavy, bulky items as this may damage the pocket or cause passengers to trip over them.

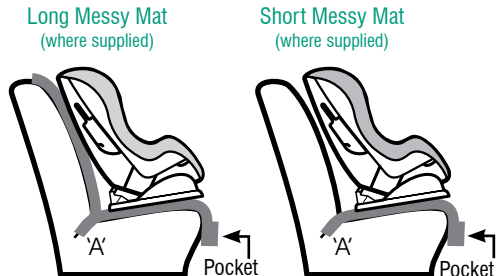

NOTE: Some messy mats may not have pockets.

SHOULDER PADS

Shoulder Pads are designed to provide extra comfort for baby or child and are easily fitted to the shoulder harness straps by:

- A. Pull apart fasteners and remove shoulder pads from harness.
- B. Re-fit shoulder pads to harness and attach fasteners for use.

BABY INSERT (IF FITTED)

Only use the insert when in Rearward Facing mode for babies. Discontinue use after baby reaches 10kg and over, Do not use when in Forward Facing mode.

- A. Disconnect buckle and place insert under shoulder and lap straps.
- B. Attach velcro hook and loops on both sides of insert.
- C. Feed the crotch strap through the flap in the baby insert and re-connect buckle.
- D. Tuck the flap underneath the baby insert.

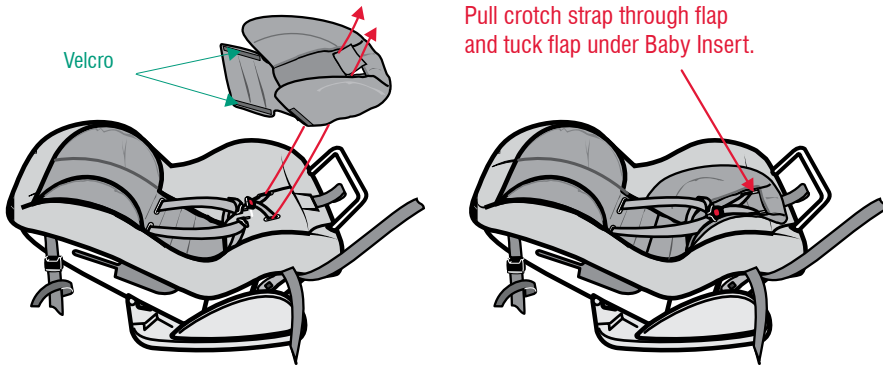

SIDE IMPACT CUSHION TECHNOLOGY™ (IF FITTED)

Side Impact Cushions are fitted to some models and are an optional safety feature only.

VEHICLE INSTALLATION ACCESSORIES (Available from retailers of Safe-n-Sound products)

EXTRA ANCHOR KITS: are available if using the restraint in additional vehicles.

Re-order numbers: 0038.

EXTENSION STRAPS: may be required for vehicles without a fixed parcel shelf.

Re-order numbers: 0035 (length 300 mm) 0036 (length 600 mm)

GATED 3-BAR SLIDE: for installation where the seat belt configuration does not firmly hold the child restraint.

Re-order number: 0215.

IN CASE OF ACCIDENT

If your restraint has been involved in a severe crash, you should destroy the restraint even if no damage is obvious. Some insurance companies offer vehicle insurance which covers or partially covers the replacement of your child restraint. Contact your insurance company for further details. Your insurance company may require you to keep the child restraint for assessment, **but do not use the child restraint after a severe crash**. To assist you in making an accident insurance claim cut the following statement and include it with your claim.

NOTICE TO INSURANCE COMPANY CHILD RESTRAINT INVOLVED IN AN ACCIDENT

All Safe-n-Sound child restraints are manufactured to Australian/New Zealand Standards AS/NZS1754-2004 which require us to advise users of child restraints to "Destroy the entire restraint if it has been in use in a severe crash, even if no damage is obvious". The joint Australian/New Zealand Standards committee CS/85, advise that this statement applies whether a child was in the child restraint or not. A severe crash, we consider as being one where the main body structure of the vehicle is distorted.

There is no method of determining if the restraint has been damaged and we concur with the Australian/New Zealand Standards in recommending destruction of the child restraint.

This notice is to advise you of the requirements of the Australian/New Zealand Standards and our obligation in complying with the standards. Please assist the owner of this restraint in their claim.

Britax Childcare Pty. Ltd.

(Incorporated in Victoria)

A.B.N 55 006 773 600

Head office and registered address:

99 Derby Road Sunshine Victoria 3020

PO Box 147 Sunshine Victoria 3020

Telephone: 1300 303 330

New Zealand Office

Britax Childcare NZ Limited.

PO Box 100-247 Auckland 9

Telephone: 0800 688 822





AUSTRALIA Britax Childcare Pty. Ltd.

(Incorporated in Victoria)

A.B.N 55 006 773 600

Head office and registered address:

99 Derby Road Sunshine Victoria 3020

PO Box 147 Sunshine Victoria 3020

Customer Service: 1300 303 330

New Zealand Office Britax Childcare NZ Limited.

PO Box 100-247 Auckland 9

Customer Service: 0800 688 822

P/No.2200062